

Fig.	Supply Voltage	Package Type	Max. Data Rate Mbps	Digi-Key Part No.	Price Each			T & R† Pricing 1,000
					1	25	100	
20	2.7/5.5	16-SOIC	1	ADUM1411ARWZ-ND	4.02	3.22	2.51	—
			10	ADUM1411BRWZ-ND	5.34	4.28	3.61	—
			90	ADUM3441CRWZ-ND	7.48	6.73	5.97	—
21	3.0/5.5	16-SOIC	90	ADUM3442CRWZ-ND†	7.48	6.73	5.97	—
			1	ADUM1410ARWZ-ND	4.02	3.22	2.51	—
22	4.5V/5.5	28-SOIC	10	ADUM1410BRWZ-ND	5.34	4.28	3.61	—
			5	ADUM1420BRWZ-ND	3.82	3.06	2.58	—
Dual Channel, Half Bridge Driver - 1MHz Switching Speed - RoHS Compliant								
23	4.5V/5.5	16-SOIC	—	ADUM5230ARWZ-ND	3.73	2.99	2.52	—
Quad Channel, with Integrated DC-DC Converter - RoHS Compliant								
24A	3.3/5.0	16-SOIC	1	ADUM5401ARWZ-ND	6.93	6.24	5.54	—
			25	ADUM5401CRWZ-ND	8.43	7.60	6.74	—
24B	3.3/5.0	16-SOIC	1	ADUM5402ARWZ-ND	6.93	6.24	5.54	—
			25	ADUM5402CRWZ-ND	8.43	7.60	6.74	—
24C	3.3/5.0	16-SOIC	1	ADUM5403ARWZ-ND	6.93	6.24	5.54	—
			25	ADUM5403CRWZ-ND	8.43	7.60	6.74	—
24D	3.3/5.0	16-SOIC	1	ADUM5404ARWZ-ND	6.93	6.24	5.54	—
			25	ADUM5404CRWZ-ND	8.43	7.60	6.74	—

◆ RoHS Compliant Δ Cut Tape † For Tape and Reel part number, change CT-ND to TR-ND.

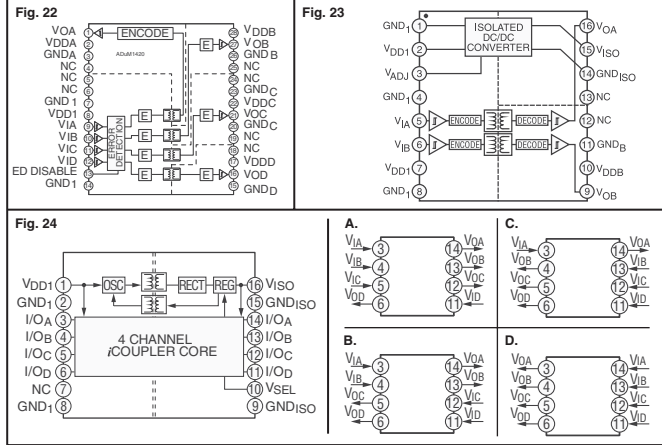
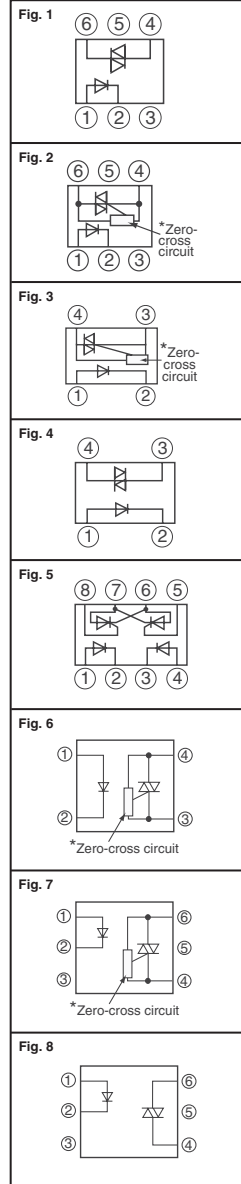

Fig.	Voltage Typ.	Input Current (mA)		Voltage V _{ORM} Max.	Output Current (mA)			Isolation Voltage Max. (Vrms)	Package Type	Digi-Key Part No.	Price Each			Sharp Part No.					
		Min.	Max.		IT (RMS) Max.	Holding Current Max.	1				10	100							
Tube																			
1	1.2	7	50	600	100	3.5	5,000	6-SMD	425-1365-5-ND	.70	.59	.47	PC3SD11NXZB						
					100	3.5	5,000	6-SMD	425-1367-5-ND	.65	.55	.44	PC3SD12NXZA						
					100	3.5	5,000	6-Dip	425-1772-5-ND†	1.02	.82	.68	S21M3DY						
		2	1.2	3	50	600	100	3.5	5,000	6-Dip	425-1373-5-ND§†	.81	.68	.54	PC3SD21YXZD				
							100	3.5	5,000	6-SMD	425-1375-5-ND§†	.93	.69	.56	PC3SD21YXZD				
							100	3.5	5,000	6-SMD	425-1371-5-ND§	.72	.60	.48	PC3SD21NXZC				
				3	1.2	5	50	600	100	3.5	5,000	6-SMD	425-1374-5-ND§†	.74	.62	.50	PC3SD21YXZC		
									100	3.5	5,000	6-DipW	425-2587-5-ND§†	.98	.82	.66	PC3SF21YVZBF		
									100	3.5	3,750	4-SMD	425-1301-5-ND†	.68	.57	.46	S2S3RY		
						4	1.2	10	50	600	100	3.5	5,000	4-DipW	425-1283-5-ND§	1.07	.89	.72	S21ME6F
											100	3.5	5,000	4-SMD	425-1285-5-ND§†	1.04	.83	.69	S21ME6Y
											100	3.5	5,000	6-DipW	425-2586-5-ND§†	.91	.77	.61	PC3SF21YVZAF
5	1.2							10	50	600	50	3.5	3,750	4-SMD	425-1303-5-ND§	.76	.64	.51	S2S4
											100	3.5	5,000	6-Dip	425-1405-5-ND§	1.02	.86	.69	PC4SD21NTZD
											100	3.5	5,000	6-DipW	425-1288-5-ND§†	1.73	1.38	1.14	S21ME8FY
		6	1.2					3	15	800	100	3.5	5,000	6-Dip	425-1289-5-ND§†	1.80	1.44	1.19	S21ME8Y
											100	3.5	5,000	6-Dip	425-1403-5-ND†	.91	.77	.61	PC4SD11NTZC
											100	3.5	5,000	6-Dip	425-1402-5-ND	.85	.71	.57	PC4SD11NTZB
				7	1.2			7	50	800	100	3.5	5,000	6-DipW	425-2593-5-ND§†	.94	.76	.63	PC4SF21YVZBF
											100	3.5	3,750	4-SMD	425-1377-5-ND§	1.11	.89	.74	PC3SG21YIZ
											100	3.5	5,000	4-Dip	425-1230-5-ND	1.05	.88	.70	S11ME5
						8	1.2	10	50	400	200	1.0	4,000	6-DipW	425-1239-5-ND†	1.23	.99	.82	S12ME1FY
											200	1.0	5,000	8-Dip	425-1238-5-ND	1.75	1.44	1.17	S12MD3
											200	1.0	2,500	8-Dip	425-1296-5-ND	1.76	1.46	1.18	S22MD3
2	1.2							7	50	600	100	3.5	5,000	4-DipW	425-2686-5-ND†	.59	.49	.40	PC3SH11YFZAF
											100	3.5	5,000	4-DipW	425-2687-5-ND§†	.70	.59	.47	PC3SH21YFZBF
											100	3.5	5,000	6-Dip	425-2618-5-ND§	1.13	.95	.76	PC4SF21YVZBF
		3	1.2					3	50	600	100	3.5	5,000	6-Dip	425-2134-5-ND§†	.81	.68	.54	PC3SD21YXZDF
											100	3.5	5,000	6-SMD	425-2125-5-ND†	.70	.59	.47	PC3SD11NXZBF
											100	3.5	5,000	6-Dip	425-2659-5-ND†	1.02	.86	.69	PC4SF11YVZBF
				4	1.2			7	50	600	100	3.5	5,000	6-Dip	425-2683-5-ND†	.89	.75	.60	PC3SF11YVZAF
											100	3.5	5,000	6-DipW	425-2684-5-ND†	.85	.71	.57	PC3SF21YVZBF
											100	3.5	5,000	6-DipW	425-2685-5-ND†	.91	.77	.61	PC3SF11YVZBF
						2	1.2	7	50	600	100	3.5	5,000	6-SMD	425-1273-1-ND	1.34	1.08	.81	S21ME3P
											100	3.5	3,750	4-SMD	425-2417-1-ND◆	.61	.51	.41	S2S3B00F
											100	3.5	3,750	4-SMD	425-2422-1-ND§†	.76	.64	.51	S2S4B00F
4	1.2							10	50	600	100	3.5	5,000	4-SMD	425-1305-1-ND§†	.76	.64	.51	S2S4BY
											100	3.5	5,000	4-SMD	425-1381-1-ND†	1.05	.88	.70	S21ME5PY
											100	3.5	3,750	4-SMD	425-2563-1-ND◆	.63	.53	.43	S2S3LA0F
		6	1.2					10	50	600	50	3.5	3,750	4-SMD	425-2564-1-ND◆§	.57	.48	.38	S2S4A00F
											100	3.5	5,000	6-Dip	425-2705-1-ND§†	.65	.55	.44	PC3SD21YXPLF
											100	3.5	5,000	6-Dip	425-2704-1-ND◆§†	.87	.73	.59	PC3SD21YXPDF
				7	1.2			5	50	800	100	3.5	5,000	6-SMD	425-2537-1-ND◆§†	1.02	.86	.69	PC4SD21YXPCF
											100	3.5	5,000	6-SMD	425-2658-1-ND◆§†	1.07	.89	.72	PC4SD21YXPDF
											100	3.5	5,000	6-SMD	425-2671-1-ND◆§†	1.00	.80	.60	PC3SD21YXPEF
						8	1.2	10	50	400	100	3.5	5,000	6-SMD	425-2573-1-ND◆	.52	.44	.35	PC2SD11NXPAF

Fig.	Voltage Typ.	Input Current (mA)		Voltage V _{ORM} Max.	Output Current (mA)			Isolation Voltage Max. (Vrms)	Package Type	Digi-Key Part No.	Tape and Reel		Sharp Part No.
		Min.	Max.		IT (RMS) Max.	Holding Current Max.	Qty.				Pricing		
Tape and Reel													
2	1.2	7	50	600	100	3.5	5,000	6-SMD	425-1273-2-ND	1,000	684.98	S21ME3P	
					50	3.5	3,750	4-SMD	425-2417-2-ND◆	3,000	249.01M	S2S3B00F	
					50	3.5	3,750	4-SMD	425-2422-2-ND◆§†	750	247.75	S2S4B00F	
4	1.2	10	50	600	100	3.5	5,000	4-SMD	425-1381-2-ND†	2,000	453.03M	S21ME5PY	
					50	3.5	3,750	4-SMD	425-2563-2-ND◆	3,000	294.76M	S2S3LA0F	
					50	3.5	3,750	4-SMD	425-2564-2-ND◆§	3,000	264.27M	S2S4A00F	
6	1.2	10	50	600	100	3.5	5,000	6-Dip	425-2705-2-ND◆§†	1,000	283.14	PC3SD21YXPLF	
					100	3.5	5,000	6-Dip	425-2704-2-ND◆§†	1,000	377.52	PC3SD21YXPDF	
					100	3.5	5,000	6-SMD	425-2537-2-ND◆§†	1,000	443.59	PC4SD21YXPCF	
7	1.2	5	50	800	100	3.5	5,000	6-SMD	425-2658-2-ND◆§†	1,000	498.04	PC4SD21YXPDF	
					100	3.5	5,000	6-SMD	425-2671-2-ND◆§†	1,000	519.09	PC3SD21YXPEF	
					100	3.5	5,000	6-SMD	425-2573-2-ND◆	1,000	243.94	PC2SD11NXPAF	

◆ RoHS Compliant § Built-in zero cross circuit † Din/VDE 0884



N

Digi-Reel® Most SMT cutdown parts are available on a Digi-Reel®. For Digi-Reel part number, change 1-ND to 6-ND or CT-ND to DKR-ND. See Digi-Key® Services on page 2 for additional information.

Free shipping on orders over £50! All prices are in British pound sterling and include duties.

uk.digikey.com — FREEPHONE: 0-800-587-0991 • 0-800-904-7786 — FREEFAX: 0-800-587-0992 • 0-800-904-7783

(UK091) 2219