

Fig.	Detector		Sensing Distance (mm)	Terminal Type	Digi-Key Part No.	Tube Price Each			Sharp Part No.
	VCC (V) Max.	Icc (mA) Max.				1	10	100	
1	5.5	16.5	5.0	Connector	425-1771-5-ND	2.19	1.83	1.46	GP1A073LCS
2	5.5	20.0	50.0	Connector	425-2565-ND	1.85	1.48	1.23	GP1A75E3J00F
3	5.25	30.0	2.0 - 22.0	Connector	425-2529-ND	4.68	3.85	3.12	GP2A240LCS0F
4	17.0	50.0	5.0	PCB	425-1952-5-ND NEW!	1.55	1.24	1.03	GP1A58HRJ00F

§ Inverted

Reflective Photointerrupter

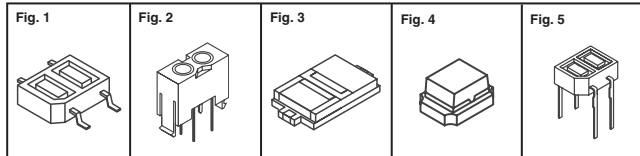

Fig.	Detector		Rise/Fall (µs) Typ.	Sensing Distance (mm)	Terminal Type	Digi-Key Part No.	Tube Price Each			Sharp Part No.
	Vceo (V) Max.	IC (mA) Max.					1	10	100	
1	35	20	20/20	0.6 - 0.8	SMD	425-1094-1-ND†	1.11	.93	.74	GP2S27T
	35	20	100	0.7	SMD	425-2569-1-ND† 425-2569-2-ND‡	1.20	1.00	.80	GP2S27T2J00F GP2S27T2J00F
	35	20	100	0.7	SMD	425-2570-1-ND† 425-2570-2-ND‡	1.17	.98	.78	GP2S27T3J00F GP2S27T3J00F
2	35	20	20/30	6	PCB	425-1095-5-ND◆	1.28	1.02	.85	GP2S28
	35	20	20/20	1	SMD	425-1097-1-ND† 425-1097-2-ND‡	.51	.43	.34	GP2S60 GP2S60
3	35	20	20/20	0.7	SMD	425-2670-1-ND† 425-2670-2-ND‡	.54	.45	.36	GP2S60B GP2S60B
	35	20	20/20	0.7	SMD	425-1913-1-ND† 425-1913-2-ND‡	1.17	.98	.78	GP2S700HCP GP2S700HCP
4	35	20	20/20	1.2 - 5.5	SMD	425-1913-1-ND† 425-1913-2-ND‡	1.17	.98	.78	GP2S700HCP GP2S700HCP
	35	20	100	0.7	PCB	425-2567-5-ND◆ 425-2568-5-ND◆	.90	.75	.60	GP2S24BJ000F GP2S24CJ000F
5	35	20	20/20	0.7	PCB	425-2681-5-ND◆ 425-2050-5-ND◆	.84	.70	.56	GP2S24BCJ00F GP2S24J000F

◆ RoHS Compliant † Cut Tape ‡ Tape and Reel

Photointerrupter

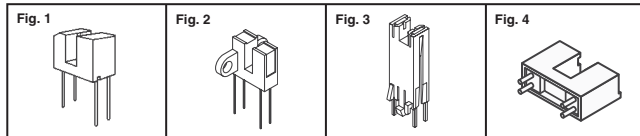
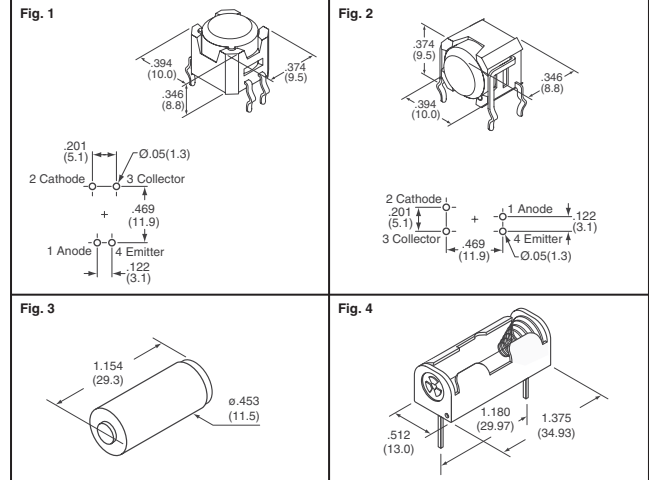

Fig.	Detector		Rise/Fall (µs) Typ.	Sensing Distance (mm)	Terminal Type	Digi-Key Part No.	Tube Price Each			Sharp Part No.
	Vceo (V) Max.	IC (mA) Max.					1	10	100	
1	35	20	35/35	1.6	PCB	425-1978-5-ND◆	1.23	1.03	.82	GP1S95J000F
	35	20	35/35	1.6	PCB	425-1062-5-ND	1.23	1.03	.82	GP1S95
	35	20	50/50	3.0	PCB	425-1040-5-ND	.56	.39	.28	GP1S094HCZ
	35	20	50/50	3.0	PCB	425-1964-5-ND◆	.56	.39	.28	GP1S094HCZ0F
	35	20	150/150	1.1	PCB	425-2509-5-ND◆*	.56	.39	.28	GP1S196HCZ0F
	35	20	150/150	1.1	SMT	425-2510-5-ND◆*	.68	.47	.34	GP1S196HCZSF
2	35	20	3/4	3.0	PCB	425-1970-5-ND◆	1.05	.88	.70	GP1S51VJ000F
3	35	20	3/4	3.0	PCB	425-1055-5-ND	.81	.68	.54	GP1S563
4	10	20	2/2	5.0	PCB	425-2680-5-ND◆	1.00	.69	.50	GP1S525VJ00F

◆ RoHS Compliant * Low profile



Dim. in Inches(mm)



DSB SERIES: Photointerrupter, rather than contacts, ensures high reliability. Sealed construction for protection from environmental elements, including hydrogen sulfide, sulfur dioxide, and nitrogen dioxide. Terminals are made of ammonia resistant materials. The switch is triggered when tilted beyond 30° in any direction.

Specifications: • Mechanical and Electrical Life: 150,000 Operations Minimum • Forward Current: 20mA • Forward Voltage: 1.3V • Operating Temperature: -25°C - 80°C
Note: Prevent exposure to magnetic fields. Do not install switch near vibration source.

DSA SERIES: • Environmentally friendly, contains no mercury • High contact reliability due to sealed body • The switch is triggered when tilted beyond ±10° of the horizontal
Specifications: • Resistive Load: 0.1A@12VDC • Mechanical Life: 100,000 operations minimum • Operating Temperature: -10°C - 70°C

Fig.	Description	Digi-Key Part No.	Price Each			NKK Part No.
			1	25	100	
1	Tilt Switch, Straight	360-2187-ND	6.19	4.12	3.69	DSBA1P
2	Tilt Switch, Right Angle	360-2188-ND	6.19	4.12	3.69	DSBA1H
3	Tilt Switch, SPST, On/Off	360-2291-ND	7.80	5.19	4.65	DSA01
4	PCB Adaptor for DSA01	360-2292-ND	1.64	1.09	.98	AT094

TOSHIBA

Illumination Sensors



SMD Photo-ICs for illuminance sensor which consist of one chip integrated photo-diode and amplifier circuit
Features: • Small SMD package • Suitable for lead-free soldering and reflow soldering • Low supply voltage: VCC = 2.7V to 5.5V

Dim in mm

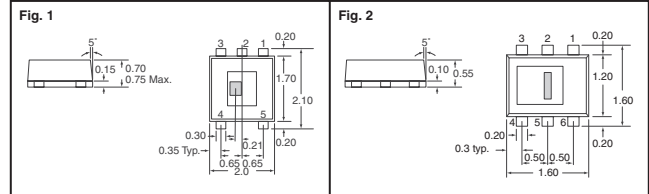

Fig.	Sensitivity	Digi-Key Part No.	Cut Tape Pricing		Tape and Reel Pricing* 3,000	Toshiba Part No.
			1	100		
1	52µA	TPS851CT-ND	1.08	9.00	72.00	TPS851
2	40µA	TPS852CT-ND	1.08	9.00	72.00	TPS852

* For Tape and Reel part number, change CT-ND to TR-ND.

JST

Mating Connector, Contact and Crimp Tool

Description	Digi-Key Part No.	Pricing			Tape & Reel Pricing*	JST Part No.
		10	100	500		
3-Pos., 2.5mm, Disconnectable Crimp Style NH Connector	455-1120-ND◆	.66	5.51	22.02	—	H3P-SHF-AA
Tin-Plated Phosphor Bronze Crimp Contact, 22-28AWG	455-1121-1-ND◆	—	3.39	13.55	101.63/5,000	SHF-001T-0.8BS
Crimp Tool with Die for 22-28AWG Contacts	455-1122-ND	—	419.19/1	—	—	WC-122

◆ RoHS Compliant * For Tape and Reel part number, change 1-ND to 2-ND.

More Product Available Online: www.digkey.com

Toll-Free: 1-800-344-4539 • Phone 218-681-6674 • Fax: 218-681-3380