

| 图 | 封装类型        | 发射颜色 | 透镜    | 波长 (nm) | 正向电压 (标准) (V) | 标准正向电流 (mA) | 流明强度 (mcd IF 时) (mA) | 视角  | Digi-Key 零件编号  | 剪切带价格 |                |        | 带卷▲   |          | Rohm 零件编号      |
|---|-------------|------|-------|---------|---------------|-------------|----------------------|-----|----------------|-------|----------------|--------|-------|----------|----------------|
|   |             |      |       |         |               |             |                      |     |                | 1     | 25             | 100    | 数量    | 价格       |                |
| 1 | 3.0mm       | 绿    | 无色透明  | 563     | 2.2           | 25          | 100 20               | 25° | 511-1191-ND‡   | .53   | 6.53           | 21.25  | —     | —        | SLA-370MT3F    |
|   |             | 红    | 无色透明  | 660     | 1.75          | 50          | 100 20               | 25° | 511-1190-ND‡   | .53   | 6.53           | 21.25  | —     | —        | SLA-370LT3F    |
| 2 | 3.1mm       | 绿    | 无色透明  | 563     | 2.2           | 25          | 100 20               | 40° | 511-1189-ND‡   | .61   | 7.48           | 24.32  | —     | —        | SLA-360MT3F    |
|   |             | 红    | 无色透明  | 660     | 1.75          | 50          | 68 20                | 40° | 511-1188-ND‡   | .61   | 7.48           | 24.32  | —     | —        | SLA-360LT3F    |
| 3 | 3.1mm       | 红    | 散射    | 630     | 1.9           | 50          | 350 20               | 40° | 511-1210-ND‡   | .80   | 9.80           | 31.87  | —     | —        | SLI-343UR3F    |
|   |             | 红    | 透明    | 630     | 1.9           | 50          | 450 20               | 40° | 511-1211-ND‡   | .80   | 9.80           | 31.87  | —     | —        | SLI-343URC3F   |
|   |             | 橙    | 散射    | 611     | 1.9           | 50          | 350 20               | 40° | 511-1209-ND‡   | .80   | 9.80           | 31.87  | —     | —        | SLI-343DU3F    |
|   |             | 橙    | 透明    | 611     | 1.9           | 50          | 500 20               | 40° | 511-1208-ND‡   | .80   | 9.80           | 31.87  | —     | —        | SLI-343DC3F    |
|   |             | 黄    | 散射    | 591     | 1.9           | 50          | 300 20               | 40° | 511-1213-ND‡   | .80   | 9.80           | 31.87  | —     | —        | SLI-343Y3F     |
|   |             | 黄    | 透明    | 591     | 1.9           | 50          | 350 20               | 40° | 511-1212-ND‡   | .80   | 9.80           | 31.87  | —     | —        | SLI-343Y3CF    |
|   |             | 红    | 散射    | 650     | 2             | 20          | 16 10                | 40° | 511-1256-1-ND§ | .33   | 3.36           | 11.32  | 2,000 | 78.00/M  | SLR-343VRT32   |
|   |             | 红    | 透明    | 650     | 2             | 20          | 25 10                | 40° | 511-1255-1-ND§ | .33   | 3.36           | 11.32  | 2,000 | 78.00/M  | SLR-343VCT32   |
|   |             | 黄    | 散射    | 585     | 2.1           | 20          | 10 10                | 40° | 511-1258-1-ND§ | .33   | 3.36           | 11.32  | 2,000 | 78.00/M  | SLR-343YRT32   |
|   |             | 黄    | 透明    | 585     | 2.1           | 20          | 16 10                | 40° | 511-1257-1-ND§ | .33   | 3.36           | 11.32  | 2,000 | 78.00/M  | SLR-343YCT32   |
|   |             | 绿    | 散射    | 563     | 2.1           | 25          | 16 10                | 40° | 511-1254-1-ND§ | .33   | 3.36           | 11.32  | 2,000 | 78.00/M  | SLR-343MGT32   |
|   |             | 绿    | 透明    | 563     | 2.1           | 25          | 25 10                | 40° | 511-1253-1-ND§ | .33   | 3.36           | 11.32  | 2,000 | 78.00/M  | SLR-343MCT32   |
|   |             | 绿    | 无色透明  | 518     | 3.8           | 20          | 2,000 20             | 40° | 511-1367-ND‡   | 1.92  | 28.33          | 96.60  | —     | —        | SLR343ECT3F    |
|   |             | 绿    | 无色透明  | 523     | 3.5           | 30          | 1,500 20             | 40° | 511-1268-ND‡   | 2.05  | 30.28          | 102.00 | —     | —        | SLR343EBT3F    |
|   |             | 绿    | 无色透明  | 468     | 3.5           | 30          | 1,500 20             | 40° | 511-1512-ND‡   | 1.89  | 27.03          | 93.51  | —     | —        | SLR343ECAT3F   |
|   |             | 4    | 3.1mm | 蓝       | 无色透明          | 468         | 3.5                  | 20  | 600 20         | 40°   | 511-1368-ND‡   | 2.16   | 31.87 | 108.68   | —              |
| 蓝 | 无色透明        |      |       | 468     | 3.5           | 30          | 200 20               | 40° | 511-1267-ND‡   | 2.05  | 30.28          | 102.00 | —     | —        | SLR343BBT3F    |
| 蓝 | 无色透明        |      |       | 468     | 3.5           | 30          | 200 20               | 40° | 511-1511-ND‡   | 1.89  | 27.03          | 93.51  | —     | —        | SLR343BCAT3F   |
| 红 | 散光          |      |       | 650     | 2             | 16          | 10 40                | 40° | 511-1250-ND‡   | .27   | 3.10           | 9.00   | —     | —        | SLR-342VR3F    |
| 红 | 透明          |      |       | 650     | 2             | 20          | 25 10                | 40° | 511-1249-ND‡   | .36   | 3.62           | 12.20  | —     | —        | SLR-342VC3F    |
| 橙 | 散射          |      |       | 610     | 2             | 20          | 16 10                | 40° | 511-1246-ND‡   | .36   | 3.62           | 12.20  | —     | —        | SLR-342DU3F    |
| 橙 | 透明          |      |       | 610     | 2             | 20          | 25 10                | 40° | 511-1245-ND‡   | .36   | 3.62           | 12.20  | —     | —        | SLR-342DC3F    |
| 黄 | 散射          |      |       | 585     | 2.1           | 20          | 10 10                | 40° | 511-1252-ND‡   | .31   | 3.11           | 10.45  | —     | —        | SLR-342Y3F     |
| 5 | 3.1 x 2.0mm | 黄    | 透明    | 585     | 2.1           | 20          | 16 10                | 40° | 511-1251-ND‡   | .36   | 3.62           | 12.20  | —     | —        | SLR-342YC3F    |
|   |             | 绿    | 散射    | 563     | 2.1           | 25          | 16 10                | 40° | 511-1248-ND‡   | .31   | 3.11           | 10.45  | —     | —        | SLR-342MG3F    |
|   |             | 绿    | 透明    | 563     | 2.1           | 25          | 25 10                | 40° | 511-1247-ND‡   | .36   | 3.62           | 12.20  | —     | —        | SLR-342MC3F    |
|   |             | 红    | 散射    | 650     | 2             | 20          | 10 10                | 55° | 511-1228-ND‡   | .31   | 3.80           | 11.43  | —     | —        | SLR-322VR3F    |
|   |             | 红    | 透明    | 650     | 2             | 20          | 16 10                | 35° | 511-1227-ND‡   | .31   | 3.80           | 11.43  | —     | —        | SLR-322VC3F    |
|   |             | 橙    | 散射    | 610     | 2             | 20          | 6.3 10               | 55° | 511-1224-ND‡   | .31   | 3.80           | 11.43  | —     | —        | SLR-322DU3F    |
|   |             | 橙    | 透明    | 610     | 2             | 20          | 16 10                | 35° | 511-1223-ND‡   | .31   | 3.80           | 11.43  | —     | —        | SLR-322DC3F    |
|   |             | 黄    | 散射    | 585     | 2.1           | 20          | 10 10                | 55° | 511-1230-ND‡   | .31   | 3.80           | 11.43  | —     | —        | SLR-322Y3F     |
|   |             | 黄    | 透明    | 585     | 2.1           | 20          | 10 10                | 35° | 511-1229-ND‡   | .31   | 3.80           | 11.43  | —     | —        | SLR-322YC3F    |
|   |             | 绿    | 散射    | 563     | 2.1           | 25          | 10 10                | 55° | 511-1226-ND‡   | .31   | 3.80           | 11.43  | —     | —        | SLR-322MG3F    |
|   |             | 绿    | 透明    | 563     | 2.1           | 25          | 25 10                | 35° | 511-1225-ND‡   | .31   | 3.80           | 11.43  | —     | —        | SLR-322MC3F    |
|   |             | 6    | 3.2mm | 红       | 散射            | 630         | 1.85                 | 20  | 100 20         | 40°   | 511-1205-1-ND§ | .76    | 9.36  | 30.46    | 2,000          |
| 红 | 透明          |      |       | 630     | 1.85          | 20          | 100 20               | 40° | 511-1204-1-ND§ | .76   | 9.36           | 30.46  | 2,000 | 227.00/M | SLI-325URCT31W |
| 橙 | 散射          |      |       | 611     | 1.9           | 20          | 100 20               | 40° | 511-1203-1-ND§ | .76   | 9.36           | 30.46  | 2,000 | 227.00/M | SLI-325DUT31W  |
| 橙 | 透明          |      |       | 611     | 1.9           | 20          | 100 20               | 40° | 511-1202-1-ND§ | .76   | 9.36           | 30.46  | 2,000 | 227.00/M | SLI-325DCT31W  |
| 黄 | 散射          |      |       | 590     | 1.9           | 20          | 100 20               | 40° | 511-1207-1-ND§ | .76   | 9.36           | 30.46  | 2,000 | 227.00/M | SLI-325YTT31W  |
| 黄 | 透明          |      |       | 590     | 1.9           | 20          | 100 20               | 40° | 511-1206-1-ND§ | .76   | 9.36           | 30.46  | 2,000 | 227.00/M | SLI-325YCT31W  |
| 红 | 散射          |      |       | 650     | 2             | 20          | 10 10                | 40° | 511-1234-1-ND§ | .41   | 5.00           | 15.07  | 2,000 | 109.00/M | SLR-325VRT31   |
| 红 | 透明          |      |       | 650     | 2             | 20          | 16 10                | 40° | 511-1233-1-ND§ | .41   | 5.00           | 15.07  | 2,000 | 109.00/M | SLR-325VCT31   |
| 黄 | 散射          |      |       | 585     | 2.1           | 20          | 6.3 10               | 40° | 511-1236-1-ND§ | .41   | 5.00           | 15.07  | 2,000 | 109.00/M | SLR-325YRT31   |
| 黄 | 透明          |      |       | 585     | 2.1           | 20          | 16 10                | 40° | 511-1235-1-ND§ | .41   | 5.00           | 15.07  | 2,000 | 109.00/M | SLR-325YCT31   |
| 绿 | 散射          |      |       | 563     | 2.1           | 25          | 16 10                | 40° | 511-1232-1-ND§ | .41   | 5.00           | 15.07  | 2,000 | 109.00/M | SLR-325MGT31   |
| 绿 | 透明          |      |       | 563     | 2.1           | 25          | 25 10                | 40° | 511-1231-1-ND§ | .41   | 5.00           | 15.07  | 2,000 | 109.00/M | SLR-325MCT31   |
| 7 | 3.2mm       | 红    | 散射    | 650     | 2             | 20          | 10 10                | 85° | 511-1242-ND‡   | .36   | 3.62           | 12.20  | —     | —        | SLR-332VR3F    |
|   |             | 橙    | 透明    | 650     | 2             | 20          | 10 10                | 75° | 511-1241-ND‡   | .36   | 3.62           | 12.20  | —     | —        | SLR-332VC3F    |
|   |             | 橙    | 散射    | 610     | 2             | 20          | 10 10                | 85° | 511-1238-ND‡   | .36   | 3.62           | 12.20  | —     | —        | SLR-332DU3F    |
|   |             | 黄    | 透明    | 610     | 2             | 20          | 16 10                | 75° | 511-1237-ND‡   | .36   | 3.62           | 12.20  | —     | —        | SLR-332DC3F    |
|   |             | 黄    | 散射    | 585     | 2.1           | 20          | 6.3 10               | 85° | 511-1244-ND‡   | .36   | 3.62           | 12.20  | —     | —        | SLR-332Y3F     |
|   |             | 绿    | 透明    | 585     | 2.1           | 20          | 10 10                | 75° | 511-1243-ND‡   | .36   | 3.62           | 12.20  | —     | —        | SLR-332YC3F    |
|   |             | 绿    | 散射    | 563     | 2.1           | 25          | 16 10                | 85° | 511-1240-ND‡   | .36   | 3.62           | 12.20  | —     | —        | SLR-332MG3F    |
|   |             | 绿    | 透明    | 563     | 2.1           | 25          | 16 10                | 75° | 511-1239-ND‡   | .36   | 3.62           | 12.20  | —     | —        | SLR-332MC3F    |
| 8 | 5mm         | 红    | 无色透明  | 660     | 1.75          | 50          | 220 20               | 25° | 511-1194-ND‡   | .61   | 7.48           | 24.32  | —     | —        | SLA-570LT3F    |
|   |             | 绿    | 无色透明  | 563     | 2.2           | 25          | 185 20               | 25° | 511-1195-ND‡   | .37   | 4.49           | 13.51  | —     | —        | SLA-570MT3F    |
|   |             | 红    | 无色透明  | 630     | 1.9           | 50          | 3,000 20             | 25° | 511-1218-ND‡   | .50   | 6.04           | 18.18  | —     | —        | SLI-570UT3F    |
|   |             | 橙    | 无色透明  | 611     | 1.9           | 50          | 3,000 20             | 25° | 511-1217-ND‡   | .54   | 6.64           | 20.00  | —     | —        | SLI-570DT3F    |
|   |             | 黄    | 无色透明  | 591     | 1.9           | 50          | 2,500 20             | 25° | 511-1219-ND‡   | .54   | 6.64           | 20.00  | —     | —        | SLI-570YT3F    |

‡ 散装 § 将 -1-ND 改为 -3-ND, 即为带盒包装的零件编号; 显示带盒价格。

▲ 将 -1-ND 改为 -2-ND, 即为带卷包装的零件编号。

(转下页)



Digi-Reel® 大多数 SMT 削减零件都可在 Digi-Reel® 上找到。将 1-ND 改为 6-ND, 或将 CT-ND 改为 DKR-ND, 即为 Digi-Reel 的零件编号。请参见第 2 页上的 Digi-Key® 服务以获得更多信息。

**全部产品均以美元计价。** 免费电话: 10800-1527031 (China Telecom - 中国电讯) — 10800-8527031 (CNCG - 中国网通)

digikkey.com.cn — 电话: (852) 3104 0500 — 传真: (852) 3104 0686

(CN082-09) **2455**

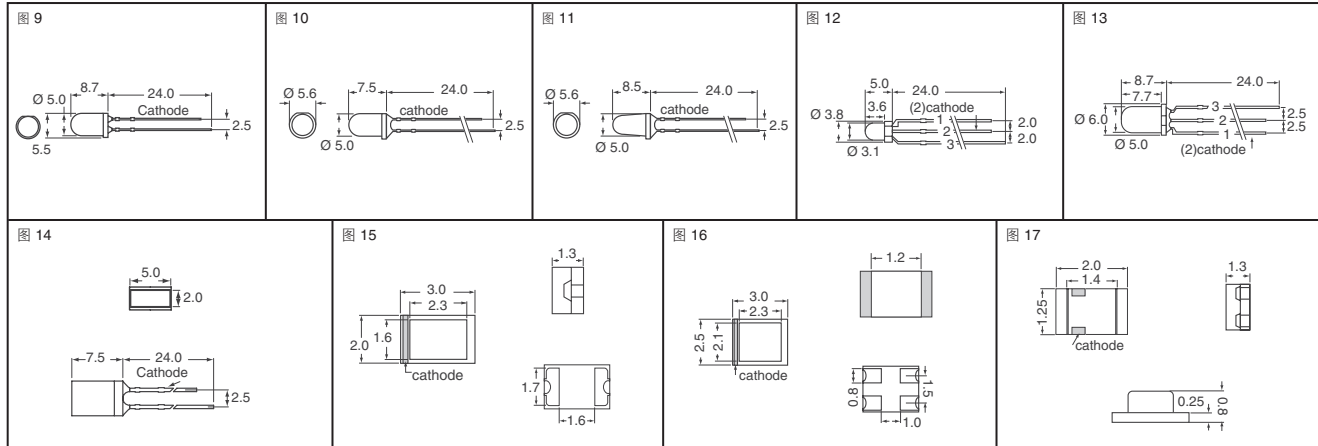

| 图   | 封装类型        | 发射颜色 | 透镜        | 波长 (nm) | 正向电压 (V) | 标准正向电流 (mA) | 流明强度   |              | 视角     | Digi-Key 零件编号 | 剪切带价格  |               |        | 带卷▲         |          | Rohm 零件编号     |
|-----|-------------|------|-----------|---------|----------|-------------|--------|--------------|--------|---------------|--------|---------------|--------|-------------|----------|---------------|
|     |             |      |           |         |          |             | mcd    | lf 时 (mA)    |        |               | 1      | 25            | 100    | 数量          | 价格       |               |
| 9   | 5mm         | 红    | 散射        | 650     | 2        | 20          | 10     | 10           | 40°    | 511-1264-ND†  | .33    | 3.36          | 11.32  | —           | —        | SLR-56VR3F    |
|     |             | 红    | 透明        | 650     | 2        | 20          | 25     | 10           | 35°    | 511-1263-ND†  | .34    | 4.14          | 12.47  | —           | —        | SLR-56VC3F    |
|     |             | 橙    | 散射        | 610     | 2        | 20          | 10     | 10           | 40°    | 511-1259-ND†  | .34    | 4.14          | 12.47  | —           | —        | SLR-56DU3F    |
|     |             | 橙    | 透明        | 610     | 2        | 20          | 25     | 10           | 35°    | 511-1258-ND†  | .34    | 4.14          | 12.47  | —           | —        | SLR-56DC3F    |
|     |             | 黄    | 散射        | 585     | 2.1      | 20          | 10     | 10           | 40°    | 511-1266-ND†  | .33    | 3.36          | 11.32  | —           | —        | SLR-56Y3F     |
|     |             | 黄    | 透明        | 585     | 2.1      | 20          | 25     | 10           | 35°    | 511-1265-ND†  | .34    | 4.14          | 12.47  | —           | —        | SLR-56YC3F    |
| 10  | 5mm         | 蓝    | 无色透明      | 468     | 3.5      | 30          | 150    | 20           | 40°    | 511-1513-ND†  | 1.66   | 23.00         | 80.50  | —           | —        | SLA560BC4T3F  |
|     |             | 绿    | 无色透明      | 523     | 3.5      | 30          | 680    | 20           | 40°    | 511-1199-ND†  | 2.05   | 30.28         | 102.00 | —           | —        | SLA560EBT3F   |
|     |             | 绿    | 无色透明      | 523     | 3.5      | 30          | 680    | 20           | 40°    | 511-1514-ND†  | 1.66   | 23.00         | 80.50  | —           | —        | SLA560EC4T3F  |
|     |             | 红    | 无色透明      | 660     | 1.75     | 50          | 100    | 20           | 40°    | 511-1192-ND†  | .50    | 7.25          | 21.82  | —           | —        | SLA-560LT3F   |
|     |             | 绿    | 无色透明      | 563     | 2.2      | 25          | 100    | 20           | 40°    | 511-1193-ND†  | .46    | 5.61          | 16.89  | —           | —        | SLA-560MT3F   |
|     |             | 红    | 无色透明      | 630     | 1.9      | 50          | 1,000  | 20           | 40°    | 511-1215-ND†  | .50    | 6.12          | 18.44  | —           | —        | SLI-560UT3F   |
|     |             | 橙    | 无色透明      | 611     | 1.9      | 50          | 1,000  | 20           | 40°    | 511-1214-ND†  | .54    | 6.64          | 20.00  | —           | —        | SLI-560DT3F   |
|     |             | 黄    | 无色透明      | 591     | 1.9      | 50          | 1,000  | 20           | 40°    | 511-1216-ND†  | .54    | 6.64          | 20.00  | —           | —        | SLI-560YT3F   |
|     |             | 蓝    | 无色透明      | 468     | 3.5      | 30          | 1,000  | 20           | 16°    | 511-1200-ND†  | 2.05   | 30.28         | 102.00 | —           | —        | SLA580BBT3F   |
|     |             | 蓝    | 无色透明      | 468     | 3.5      | 30          | 1,000  | 20           | 16°    | 511-1515-ND†  | 1.66   | 23.00         | 80.50  | —           | —        | SLA580BC4T3F  |
|     |             | 蓝    | 无色透明      | 468     | 3.5      | 20          | 2,500  | 20           | 12°    | 511-1370-ND†  | 2.13   | 31.46         | 107.27 | —           | —        | SLA580BCT3F   |
|     |             | 绿    | 无色透明      | 523     | 3.5      | 30          | 4,500  | 20           | 16°    | 511-1516-ND†  | 1.66   | 23.00         | 80.50  | —           | —        | SLA580EC4T3F  |
| 绿   | 无色透明        | 518  | 3.8       | 20      | 8,000    | 20          | 12°    | 511-1369-ND† | 2.40   | 35.41         | 120.75 | —             | —      | SLA580ECT3F |          |               |
| 11  | 5mm         | 红    | 无色透明      | 660     | 1.75     | 50          | 470    | 20           | 10°    | 511-1196-ND†  | .50    | 7.25          | 21.82  | —           | —        | SLA-580LT3F   |
|     |             | 绿    | 无色透明      | 563     | 2.2      | 25          | 470    | 20           | 10°    | 511-1197-ND†  | .41    | 5.00          | 15.07  | —           | —        | SLA-580MT3F   |
|     |             | 红    | 无色透明      | 630     | 1.9      | 50          | 5,000  | 20           | 10°    | 511-1221-ND†  | .54    | 6.64          | 20.00  | —           | —        | SLI-580UT3F   |
|     |             | 橙    | 无色透明      | 611     | 1.9      | 50          | 5,000  | 20           | 10°    | 511-1220-ND†  | .54    | 6.64          | 20.00  | —           | —        | SLI-580DT3F   |
|     |             | 黄    | 无色透明      | 591     | 1.9      | 50          | 5,000  | 20           | 10°    | 511-1222-ND†  | .54    | 6.64          | 20.00  | —           | —        | SLI-580YT3F   |
|     |             | 黄    | 无色透明      | 591     | 1.9      | 50          | 5,000  | 20           | 10°    | 511-1222-ND†  | .54    | 6.64          | 20.00  | —           | —        | SLI-580YT3F   |
| 12  | 3.1mm       | 红/绿  | 乳白        | 650/563 | 2/2.1    | 20/25       | 6.3/10 | 10           | 60°    | 511-1334-ND†  | .61    | 7.48          | 24.32  | —           | —        | SPR-39MVWF    |
| 13  | 5mm         | 红/绿  | 乳白        | 650/563 | 2/2.1    | 20/25       | 6.3/10 | 10           | 40°    | 511-1335-ND†  | .82    | 10.09         | 32.82  | —           | —        | SPR-54MVWF    |
| 14  | 2.0 x 5.0mm | 橙    | 散射        | 610     | 2.0      | 20          | 1.0    | 10           | 130°   | 511-1605-ND†  | .38    | 4.57          | 13.77  | —           | —        | SLB-25DU3F    |
|     |             | 绿    | 散射        | 563     | 2.1      | 25          | 1.0    | 10           | 130°   | 511-1606-ND†  | .38    | 4.57          | 13.77  | —           | —        | SLB-25MG3F    |
|     |             | 红    | 散射        | 650     | 2.0      | 20          | 1.0    | 10           | 130°   | 511-1607-ND†  | .38    | 4.57          | 13.77  | —           | —        | SLB-25VR3F    |
| 15  | 3 x 2mm     | 蓝    | 无色透明      | 428     | 3.8      | 20          | 9      | 20           | 110°   | 511-1328-1-ND | 1.09   | 15.00         | 49.07  | 2,500       | 389.00/M | SML010BAT86   |
|     |             | 红    | 无色透明      | 660     | 1.75     | 30          | 16     | 20           | 110°   | 511-1271-1-ND | .38    | 4.66          | 14.03  | 2,500       | 101.00/M | SML-010LT86   |
|     |             | 红    | 无色透明      | 650     | 2        | 30          | 6.3    | 20           | 110°   | 511-1274-1-ND | .37    | 4.49          | 13.51  | 2,500       | 98.00/M  | SML-010VT86   |
|     |             | 橙    | 无色透明      | 610     | 2        | 25          | 10     | 20           | 110°   | 511-1269-1-ND | .38    | 4.66          | 14.03  | 2,500       | 101.00/M | SML-010DT86   |
|     |             | 黄    | 无色透明      | 585     | 2.1      | 25          | 6.3    | 20           | 110°   | 511-1275-1-ND | .37    | 4.49          | 13.51  | 2,500       | 98.00/M  | SML-010YT86   |
|     |             | 绿    | 无色透明      | 570     | 2.2      | 25          | 25     | 20           | 110°   | 511-1272-1-ND | .31    | 3.80          | 11.43  | 2,500       | 83.00/M  | SML-010MT86   |
|     |             | 绿    | 无色透明      | 560     | 2.2      | 25          | 10     | 20           | 110°   | 511-1270-1-ND | .38    | 4.66          | 14.03  | 2,500       | 101.00/M | SML-010FT86   |
|     |             | 绿    | 无色透明      | 555     | 2.2      | 25          | 6.3    | 20           | 110°   | 511-1273-1-ND | .38    | 4.66          | 14.03  | 2,500       | 101.00/M | SML-010PT86   |
|     |             | 蓝    | 无色透明      | 468     | 3.5      | 20          | 2.5    | 20           | 110°   | 511-1329-1-ND | 1.81   | 22.72         | 81.78  | —           | —        | SML011BT86    |
|     |             | 蓝    | 无色透明      | 468     | 3.5      | 20          | 2.5    | 20           | 110°   | 511-1507-1-ND | 1.88   | 23.61         | 84.96  | 2,500       | 644.00/M | SML012BC4TT86 |
|     |             | 绿    | 无色透明      | 523     | 3.5      | 20          | 90     | 20           | 110°   | 511-1330-1-ND | 2.05   | 30.28         | 102.00 | —           | —        | SML011EBTT86  |
|     |             | 绿    | 无色透明      | 528     | 3.5      | 20          | 90     | 20           | 110°   | 511-1508-1-ND | 2.21   | 27.74         | 99.83  | 2,500       | 757.00/M | SML012EC4TT86 |
|     |             | 红    | 无色透明      | 630     | 2        | 30          | 63     | 20           | 110°   | 511-1276-1-ND | .53    | 6.53          | 21.25  | 2,500       | 158.00/M | SML-011UT86   |
|     |             | 红    | 无色透明      | 630     | 2        | 30          | 100    | 20           | 110°   | 511-1278-1-ND | .57    | 7.04          | 22.90  | 2,500       | 171.00/M | SML-012UT86   |
|     |             | 橙    | 无色透明      | 611     | 2        | 30          | 100    | 20           | 110°   | 511-1277-1-ND | .57    | 7.04          | 22.90  | 2,500       | 171.00/M | SML-012DT86   |
|     |             | 黄    | 无色透明      | 590     | 2        | 30          | 100    | 20           | 110°   | 511-1279-1-ND | .57    | 7.04          | 22.90  | 2,500       | 171.00/M | SML-012YT86   |
|     |             | 白    | 散射        | —       | 3.2      | 20          | 900    | 20           | 120°   | 511-1603-1-ND | 1.78   | 24.73         | 86.54  | 2,500       | 692.00/M | SML013WBDW1S  |
|     |             | 16   | 3 x 2.5mm | 红/绿     | 无色透明     | 650/570     | 2/2.2  | 30/25        | 6.3/20 | 20            | 110°   | 511-1281-1-ND | .53    | 6.53        | 21.25    | 2,500         |
| 红/绿 | 无色透明        |      |           | 660/570 | 1.75/2.2 | 30/25       | 16/20  | 20           | 110°   | 511-1280-1-ND | .53    | 6.53          | 21.25  | 2,500       | 158.00/M | SML-020MLT86  |
| 黄/绿 | 无色透明        |      |           | 585/570 | 2.1/2.2  | 30/25       | 6.3/20 | 20           | 110°   | 511-1282-1-ND | .53    | 6.53          | 21.25  | 2,500       | 158.00/M | SML-020MYT87  |
| 橙/绿 | 无色透明        |      |           | 610/555 | 2.2/2    | 30/25       | 10/4   | 20           | 110°   | 511-1283-1-ND | .57    | 7.04          | 22.90  | 2,500       | 171.00/M | SML-020PTT87  |
| 亮红  | 无色透明        |      |           | 660     | 1.75     | 30          | 10     | 20           | 140°   | 511-1286-1-ND | .30    | 3.71          | 12.49  | 3,000       | 81.00/M  | SML-210LT86   |
| 17  | 0805        | 红    | 无色透明      | 650     | 2        | 25          | 4      | 20           | 140°   | 511-1289-1-ND | .31    | 3.11          | 10.45  | 3,000       | 68.00/M  | SML-210PT86   |
|     |             | 橙    | 无色透明      | 610     | 2        | 25          | 6.3    | 20           | 140°   | 511-1284-1-ND | .30    | 3.71          | 12.49  | 3,000       | 81.00/M  | SML-210DT86   |
|     |             | 黄    | 无色透明      | 585     | 2.1      | 25          | 6.3    | 20           | 140°   | 511-1290-1-ND | .30    | 3.71          | 12.49  | 3,000       | 81.00/M  | SML-210YT86   |
|     |             | 绿    | 无色透明      | 570     | 2.2      | 25          | 16     | 20           | 140°   | 511-1287-1-ND | .31    | 3.11          | 10.45  | 3,000       | 68.00/M  | SML-210MT86   |
|     |             | 绿    | 无色透明      | 560     | 2.2      | 25          | 4      | 20           | 140°   | 511-1285-1-ND | .30    | 3.71          | 12.49  | 3,000       | 81.00/M  | SML-210FT86   |
|     |             | 红    | 无色透明      | 630     | 1.8      | 10          | 2.5    | 2            | 140°   | 511-1292-1-ND | .46    | 5.61          | 16.89  | 3,000       | 122.00/M | SML-211UT86   |
|     |             | 橙    | 无色透明      | 611     | 1.8      | 10          | 2.5    | 2            | 140°   | 511-1291-1-ND | .46    | 5.61          | 16.89  | 3,000       | 122.00/M | SML-211DT86   |
|     |             | 黄    | 无色透明      | 590     | 1.8      | 10          | 1.6    | 2            | 140°   | 511-1293-1-ND | .46    | 5.61          | 16.89  | 3,000       | 122.00/M | SML-211YT86   |
|     |             | 红    | 无色透明      | 639     | 2.05     | 30          | 63     | 20           | 140°   | 511-1295-1-ND | .50    | 7.25          | 21.82  | 3,000       | 148.00/M | SML-212VT86   |
|     |             | 橙    | 无色透明      | 611     | 2.05     | 30          | 63     | 20           | 140°   | 511-1294-1-ND | .50    | 7.25          | 21.82  | 3,000       | 148.00/M | SML-212DT86   |
|     |             | 黄    | 无色透明      | 591     | 2.05     | 30          | 63     | 20           | 140°   | 511-1296-1-ND | .50    | 7.25          | 21.82  | 3,000       | 148.00/M | SML-212YT86   |

† 散裝 § 將 -1-ND 改為 -3-ND, 即為帶盒包裝的零件編號; 顯示帶盒價格。 ▲ 將 -1-ND 改為 -2-ND, 即為帶卷包裝的零件編號。 (轉下頁)

Digi-Reel® 大多數 SMT 削減零件都可在 Digi-Reel® 上找到。將 1-ND 改為 6-ND, 或將 CT-ND 改為 DKR-ND, 即為 Digi-Reel 的零件編號。請參見第 2 頁上的 Digi-Key® 服務以獲得更多信息。