

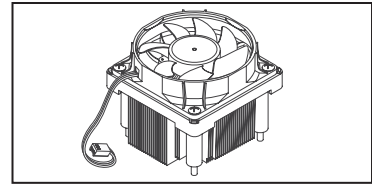

# WATURBO CPU 冷却器



液体冷却领域的世界最新创新-Sunon Waturbo 系统使用风扇电机驱动液体泵。Sunon Waturbo 使用磁耦合向散热片中的液体泵输送叶轮驱动转矩。这意味着不需要使用泵电机或其它电气零件来冷却水。

尺寸 (mm)	电压 (VDC)	气流 (CFM)	预期寿命 (小时)	Digi-Key 零件编号	单价				Sunon 零件编号
					1	10	25	50	
92 x 25	12	56	30,000	259-1437-ND	141.00	117.73	110.25	103.69	TC014-06001

## 鼓风机

特点:

- 辐射式鼓风机, 具有极佳的冷却性能并带单向排气
- 高效风扇叶片设计, 噪音低
- 采用径向间隙型电机设计, 确保低功耗和高电机效率
- 工作温度: 0°C - 70°C



图	尺寸 (mm) A x B x C	电压 (VDC)	工作电压 (VDC)	轴承类型	电流 (A)	输入 (W)	速度 (RPM)	气流 (CFM)	静态压力 (1" 或 25.4mm 时 - H <sub>2</sub> O)	噪音压力 (dBA)	Digi-Key 零件编号	单价				Sunon 零件编号
												1	10	25	50	
<b>电机鼓风机</b>																
1	75 x 75 x 30	12	6 - 13.8	滚珠	0.300	3.60	3400	13.60	0.60	43.5	259-1365-ND†	19.01	15.88	14.87	13.98	PMB1275PNB1-A(2).GN
			6 - 13.8	滚珠	0.130	1.60	2400	9.60	0.27	33.9	259-1366-ND†	19.01	15.88	14.87	13.98	PMB1275PNB3-A(2).GN
	97 x 94 x 33	12	10.2 - 13.8	滚珠	0.300	3.60	2700	22.40	0.43	50.0	259-1367-ND†	21.22	15.94	14.91	14.01	PMB1297PYB1-A(2).GN
			6 - 12	滚珠	0.720	8.60	3600	30.50	0.92	55.8	259-1367-ND†	26.39	22.04	20.64	19.41	PMB1297PYB1-A(2).GN
	120 x 120 x 32	12	10.2 - 13.8	滚珠	0.300	3.60	2700	22.40	0.43	50.0	259-1368-ND†	23.41	19.55	18.31	17.22	PMB1297PYB3-A(2).R.GN
			6 - 13.8	滚珠	0.820	9.80	2500	35.90	0.89	53.8	259-1363-ND†	30.46	25.43	23.82	22.40	PMB1212PLB2-A(2).GN
			6 - 13.8	滚珠	0.450	5.40	2100	31.40	0.64	49.6	259-1300-ND†	25.02	18.79	17.58	16.52	PMB1212PLB3-A(2).GN
			6 - 13.8	滚珠	0.450	5.40	2100	31.40	0.64	49.6	259-1364-ND†	23.08	19.27	18.05	16.97	PMB1212PLB3-A(2).GN
<b>MagLev® 环保电机鼓风机</b>																
1	50 x 50 x 15	12	6 - 13.8	汽化	0.170	2.00	6000	4.70	0.97	42.2	259-1316-ND†	10.88	9.09	8.51	8.01	GB1205PHVX-8AY.GN
			5 - 13.8	汽化	0.060	0.70	4000	3.00	0.40	33.4	259-1292-ND†	14.41	10.83	10.13	9.51	GB1205PHV2-8AY
	50 x 50 x 20	12	6 - 13.8	汽化	0.060	0.70	4000	3.00	0.40	33.4	259-1315-ND†	10.88	9.09	8.51	8.01	GB1205PHV2-8AY.GN
			6 - 13.8	汽化	0.124	1.50	5200	5.70	0.66	35.0	259-1317-ND†	10.88	9.09	8.51	8.01	GB1205PKV1-8AY.GN
	60 x 60 x 15	12	6 - 13.8	汽化	0.090	1.10	4400	4.80	0.46	30.0	259-1294-ND†	14.93	11.22	10.50	9.86	GB1205PKV3-8AY
			6 - 13.8	汽化	0.088	1.10	4400	4.80	0.46	30.0	259-1318-ND†	9.07	7.58	7.10	6.68	GB1205PKV3-8AY.GN
2	25 x 25 x 10	5	3.5 - 6	汽化	0.105	1.3	4800	5.2	0.44	40.5	259-1455-ND†	11.28	9.42	8.82	8.30	GB1206PHV1-AY.GN
	30 x 30 x 10	5	3 - 6	汽化	0.04	0.5	3200	3.5	0.18	29.0	259-1456-ND†	11.28	9.42	8.82	8.30	GB1206PHV3-AY.GN
	35 x 35 x 4.8	5	3 - 6	汽化	0.090	0.5	12000	1.00	0.30	32.0	259-1444-ND†	15.85	11.88	11.29	10.52	GB0502PFV1-8-B2393.GN
	35 x 35 x 6	5	3 - 6	汽化	0.103	0.5	10000	1.20	0.32	30.9	259-1445-ND†	20.02	15.04	14.07	13.21	GB0503PFV1-8-B1837.GN
	40 x 40 x 7	5	3 - 6	汽化	0.16	0.8	9500	0.9	0.31	31.0	259-1447-ND†	15.93	13.31	12.46	11.72	GB0535ACB1-8-B2208.GN
			3 - 5	汽化	0.12	0.6	8500	1.0	0.32	31.0	259-1448-ND†	14.36	11.70	10.96	10.30	GB0535AEV1-8-B2445.GN
	40 x 40 x 9	5	3 - 5	汽化	0.085	0.4	7800	0.90	0.23	26.2	259-1450-ND†	13.87	11.58	10.85	10.20	GB0535AEV1-8A-B1360.F.GN
			2.5 - 6	汽化	0.100	0.5	8000	1.18	0.30	29.6	259-1451-ND†	15.25	12.74	11.93	11.22	GB0535ADV1-8-B2336.GN
	45 x 45 x 9	5	3 - 5	汽化	0.080	0.4	7500	1.5	0.34	33.0	259-1452-ND†	16.00	13.37	12.52	11.77	GB0504ADV1-8-B2471.F.GN
			4 - 6	汽化	0.049	0.3	5500	1.5	0.21	24.5	259-1453-ND†	15.25	12.74	11.93	11.22	GB0504AFV1-8-B2493.GN
			3 - 6	汽化	0.070	0.35	5500	2.20	0.26	29.0	259-1446-ND†	17.40	13.07	12.23	11.48	GB0545AFV1-8-B1824.GN
<b>MagLev® 电机鼓风机</b>																
2	25 x 25 x 10	5	4 - 6	滚珠	0.12	0.60	10000	0.8	0.25	30.0	259-1167-ND†	13.75	10.31	9.80	9.13	B0502AFB2-8 (MS)
			4 - 6	滚珠	0.18	0.90	14000	1.0	0.40	37.0	259-1166-ND†	14.36	10.77	10.23	9.53	B0502AFB1-8 (MS)

◆ 符合 RoHS 规范要求 † 塑料外壳 (风扇叶 - PBT 94V-0) ‡ 铝外壳 (风扇叶 - PBT 94V-0) ◇ 锁定转子传感器 请注意: 可根据要求提供专用风扇线缆组件。

# COPAL ELECTRONICS

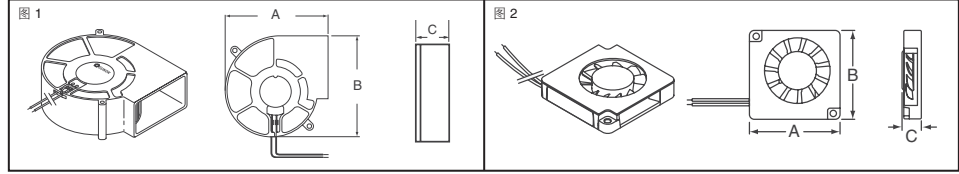

## 无刷 DC 风扇

Copal Electronics 提供一系列的无刷 DC 风扇, 尺寸从 16mm 至 62mm。设计用于便携式电子设备、汽车和医疗设备; 这些风扇特别适用于 PCB 上某些特定区域的冷却或空间有限的电子组件的冷却。

特点:

- 受专利保护的叶轮设计可改善气流并减少振动 • 低噪音, 3dBA 至 24dBA • 长寿命滚珠和/或套筒轴承设计 • 用轻便 UL 94V-0 ABS/PBT 合金制造的框架和叶轮

技术规格:

- 工作温度: -10°C - 60°C
- 存放温度: -30°C - 70°C



图	尺寸 (mm)	轴承类型	工作电压 (VDC)	电流 (A)	气流 (CFM)	噪音 (dBA)	Digi-Key 零件编号	单价				Copal Electronics 零件编号
								1	10	100	500	
1	16 x 16 x 4	套管	3.3	.02	.424	3	563-1106-ND	13.94	12.95	11.71	9.96	F16EA-03LLC /E
			5	.04	.424	3	563-1107-ND	13.94	12.95	11.71	9.96	F16FB-05LLC /E
			5	.03	.530	7	563-1108-ND	15.51	14.41	13.02	11.09	F17HA-05MC
	25 x 25 x 10	套管	5	.05	1.41	11	563-1111-ND	13.34	12.39	11.20	9.53	F251R-05LLC
			12	.03	1.41	11	563-1115-ND	13.34	12.39	11.20	9.53	F251R-12LLC
			12	.02	1.24	9	563-1117-ND	13.34	12.39	11.20	9.53	F251R-12L3C
			12	.08	1.62	12	563-1121-ND	13.34	12.39	11.20	9.53	F251T-12LLC
			5	.06	1.77	15	563-1109-ND	16.27	15.11	13.66	11.63	F251R-05LB
			5	.05	1.41	11	563-1110-ND	16.27	15.11	13.66	11.63	F251R-05LLB
		1 套管/1 滚珠	5	.04	1.24	9	563-1112-ND	16.27	15.11	13.66	11.63	F251R-05L3B
			5	.05	1.41	11	563-1119-ND	16.27	15.11	13.66	11.63	F251RF-05LLB
			12	.05	2.12	20	563-1113-ND	16.27	15.11	13.66	11.63	F251R-12MB
			12	.03	1.41	11	563-1114-ND	16.27	15.11	13.66	11.63	F251R-12LLB
			12	.02	1.24	9	563-1116-ND	16.27	15.11	13.66	11.63	F251R-12L3B
			12	.04	1.77	15	563-1118-ND	16.27	15.11	13.66	11.63	F251R-12LB
	30 x 30 x 10	套管	5	.07	3.18	17	563-1123-ND	13.34	12.39	11.20	9.53	F310R-05LC
			5	.05	2.12	13	563-1124-ND	13.34	12.39	11.20	9.53	F310R-05LLC
			12	.04	3.18	17	563-1126-ND	13.34	12.39	11.20	9.53	F310R-12LC
1 套管/1 滚珠		12	.025	2.12	13	563-1127-ND	13.34	12.39	11.20	9.53	F310R-12LLC	
		5	.07	3.18	17	563-1122-ND	16.27	15.11	13.66	11.63	F310R-05LB	
		5	.07	3.18	17	563-1128-ND	16.27	15.11	13.66	11.63	F310RF-05LB	
		12	.04	3.18	17	563-1125-ND	16.27	15.11	13.66	11.63	F310R-12LB	
		12	.04	3.18	17	563-1129-ND	16.27	15.11	13.66	11.63	F310RF-12LB	
		40 x 40 x 10	套管	5	.08	3.88	12	563-1130-ND	12.94	12.02	10.87	9.25
5		.12	5.30	18	563-1132-ND	12.94	12.02	10.87	9.25	F410T-05MC		
12		.04	3.88	12	563-1131-ND	12.94	12.02	10.87	9.25	F410T-12LC		
12		.06	5.30	18	563-1133-ND	12.94	12.02	10.87	9.25	F410T-12MC		
41 x 41 x 12.2	1 套管/1 滚珠	5	.08	3.88	16	563-1135-ND	14.94	13.88	12.54	10.68	F412R-05LB	
		5	.10	5.30	23	563-1138-ND	14.94	13.88	12.54	10.68	F412R-05MB	
		12	.04	3.53	14	563-1134-ND	14.94	13.88	12.54	10.68	F412R-12LLB	
		12	.04	3.88	16	563-1136-ND	14.94	13.88	12.54	10.68	F412R-12LB	
	12	.06	5.30	23	563-1139-ND	14.94	13.88	12.54	10.68	F412R-12MB		
	24	.03	3.88	16	563-1137-ND	14.94	13.88	12.54	10.68	F412R-24LB		
	24	.04	5.30	23	563-1140-ND	14.94	13.88	12.54	10.68	F412R-24MB		
	2	45 x 45 x 5	套管	5	.14	1.06	23	563-1141-ND	31.84	29.57	26.73	22.75

全部产品均以美元定价。 免费电话: 10800-1527031 (China Telecom - 中国电讯) — 10800-8527031 (CNCG - 中国网通)

digikey.com.cn — 电话: (852) 3104 0500 — 传真: (852) 3104 0686

(CN082-09) 2291

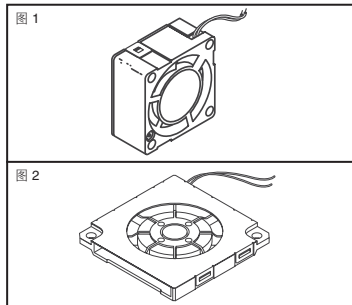
# ebmpapst 风扇

UL 黄卡 E38324、CSA 文件 27697、VDE 文件 3041、CCC (ACmaxx)、CE (ACmaxx)

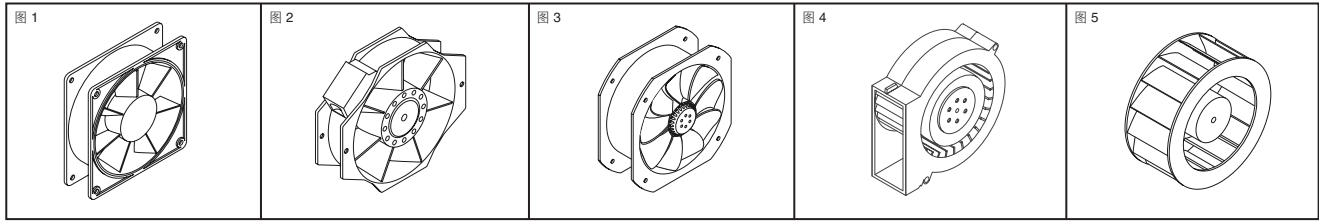

**ACmaxx 管轴风扇**：用于工业开关机柜、滤波器风扇、焊接机、冷藏柜或计数器、通风和空调系统。  
 特点：• 85 ~ 265 伏、50 和 60 Hertz，用于全球不同的电压 • ≤75% 低功耗 • 风扇集成的智能功能可提高应用的灵活性 • 大流量

图	尺寸 (mm)	轴承	电压	输入功率	值为 0 时的 CFM	dBa	引线	Digi-Key 零件编号	单价				ebmpapst Ind. 零件编号
									1	25	50	100	
<b>ACmaxx 管轴风扇 - 符合 RoHS 规范要求</b>													
1	92 x 38	滚珠	115/230	11	86	55	22 AWG 12.2" 引线	381-2284-ND	68.15	52.20	47.85	42.05	AC3200JH
	119 x 32	滚珠	115/230	11	120	51	22 AWG 12.2" 引线	381-2285-ND	60.04	45.99	42.16	37.05	AC4300H
3	178 x 165 x 50	滚珠	115/230	12	206	50	22 AWG 12.2" 引线	381-2286-ND	83.50	73.07	66.80	58.45	AC6200NM
<b>AC 管轴风扇</b>													
1	80 x 38	套管	115	8	21	21	18 AWG 12.2" 引线	381-1057-ND	39.13	29.97	27.48	24.15	8830N
		套管	115	11	28	28	18 AWG 12.2" 引线	381-1106-ND	39.60	30.33	27.81	24.44	8800N
		套管	115	11	34	41	0.110"x0.02" 端子	381-1051-ND	33.72	25.83	23.68	20.81	8500A
		套管	115	11	36	34	18 AWG 12.2" 引线	381-1103-ND	35.96	27.54	25.25	22.19	8500N
		套管	115	11	36	34	18 AWG 12.2" 引线	381-1102-ND	40.77	31.23	28.63	25.16	8500DP
		套管	230	11	36	34	18 AWG 12.2" 引线	381-1105-ND	35.72	27.36	25.08	22.04	8550N
	92 x 25	滚珠	115	9	41	40	0.110"x0.02" 端子	381-1076-ND	39.13	29.97	27.48	24.15	3906
		滚珠	115	11	52	42	18 AWG 12.2" 引线	381-1075-ND	47.71	36.54	33.50	29.44	2606
		滚珠	115	8	59	35	0.110"x0.02" 端子	381-1107-ND	42.18	32.31	29.62	26.03	9906L
		滚珠	115	12	79	42	0.110"x0.02" 端子	381-1078-ND	42.18	32.31	29.62	26.03	9906
		滚珠	230	12	79	42	0.110"x0.02" 端子	381-1079-ND	42.18	32.31	29.62	26.03	9956
		滚珠	115	12	71	32	0.110"x0.02" 端子	381-1026-ND	42.18	32.31	29.62	26.03	4530Z
	92 x 38	套管	230	19	94	40	0.110"x0.02" 端子	381-1033-ND	33.49	25.65	23.52	20.67	4650Z
		滚珠	230	19	94	40	0.110"x0.02" 端子	381-1035-ND	44.65	34.20	31.35	27.55	4656Z
		滚珠	115	18	106	50	0.110"x0.02" 端子	381-1089-ND	34.78	26.64	24.42	21.46	4600N
		滚珠	115	18	106	50	0.110"x0.02" 端子	381-1090-ND	29.02	22.23	20.38	17.91	4600X
		滚珠	230	18	106	50	0.110"x0.02" 端子	381-1093-ND	34.78	26.64	24.42	21.46	4650N
		滚珠	230	18	106	50	0.110"x0.02" 端子	381-1094-ND	32.43	24.84	22.77	20.01	4650X
	119 x 25	滚珠	115	18	106	51	0.110"x0.02" 端子	381-1091-ND	41.95	32.13	29.46	25.89	4606N
		滚珠	230	18	106	51	0.110"x0.02" 端子	381-1095-ND	42.42	32.49	29.79	26.18	4656X
		滚珠	115	18	106	45	0.118"x0.02" 端子	381-1030-ND	44.89	34.38	31.52	27.70	4606VX
		滚珠	230	18	106	45	0.118"x0.02" 端子	381-1034-ND	60.28	46.17	42.33	37.20	4656VX-B17
		滚珠	115	18	106	45	0.110"x0.02" 端子	381-1029-ND	37.48	28.71	26.32	23.13	4600Z
		滚珠	115	18	106	45	0.110"x0.02" 端子	381-1031-ND	45.71	35.01	32.10	28.21	4606Z
119 x 38	滚珠	115	18	106	45	22 AWG 12.2" 引线	381-1092-ND	48.18	36.90	33.83	29.73	4606ZW	
	滚珠	230	18	106	45	0.110"x0.02" 端子	381-1119-ND	49.82	38.16	34.98	30.74	5908-105	
	套管	115	17	121	47	0.110"x0.02" 端子	381-1120-ND	—	36.18	—	—	5900-505	
	滚珠	230	26	159	50	0.110"x0.02" 端子	381-1096-ND	—	65.70	—	—	5656S	
	滚珠	115	38	225	52	20 AWG 13.3" 引线	381-1121-ND	84.13	64.44	59.07	51.91	W2S130-AA25-01	
	滚珠	230	46	250	60	20 AWG 13.3" 引线	381-1123-ND	84.13	64.44	59.07	51.91	W2S130-BM03-01	
127 x 38	滚珠	115	46	263	60	20 AWG 13.3" 引线	381-1124-ND	76.38	58.50	53.63	47.13	W2S130-BM15-01	
	滚珠	115	26	260	58	PSC 0.11" 端子	381-1065-ND	103.52	79.29	72.69	63.88	W2E143-AA15-01	
	滚珠	230	29	295	58	PSC 0.11" 端子	381-1066-ND	108.81	83.34	76.40	67.14	W2E143-AB09-01	
	滚珠	230	28	230	57	0.11" 端子	381-1062-ND	100.93	77.31	70.87	62.28	W2E142-BB01-01	
	滚珠	115	24	230	57	0.11" 端子	381-1063-ND	132.31	101.34	92.90	81.64	W2E142-BB05-01	
	滚珠	115	80	606	61	端接块	381-2281-ND	154.40	135.10	123.52	108.08	W2E200-HK86-01	
<b>AC Flatpak 鼓风机 - 符合 RoHS 规范要求</b>													
4	121 x 37	套管	115	20	25	60	22 AWG 12.2" 引线	381-1058-ND	54.05	41.40	37.95	33.35	RL90-18/00
		套管	230	20	25	60	22 AWG 12.2" 引线	381-1061-ND	61.69	47.25	43.32	38.07	RL90-18/50

请注意：可根据要求提供专用风扇线缆组件。 ◆符合 RoHS 规范要求

图	尺寸 (mm)	电压	电压范围	轴承	瓦	值为 0 时的 CFM	dBa	引线	Digi-Key 零件编号	单价				ebmpapst Ind. 零件编号
										1	25	50	100	
<b>无刷 DC 管轴风扇</b>														
1	40 x 10	12	10-14	套管	0.8	5.3	26	28 AWG 12.2" 引线	381-1081-ND	12.93	9.90	9.08	7.98	412FH
		24	20-28	套管	0.8	4.7	22	28 AWG 12.2" 引线	381-1082-ND	13.16	10.08	9.24	8.12	414F
	40 x 20	12	10-14	套管	1.0	5.9	18	28 AWG 12.2" 引线	381-1069-ND	17.27	13.23	12.13	10.66	412
		24	20-28	套管	1.0	5.9	18	28 AWG 12.2" 引线	381-1070-ND	14.81	11.34	10.40	9.14	414
	40 x 25	12	8-14	滚珠	3.3	14	46	28 AWG 12.2" 引线	381-1125-ND	34.31	26.28	24.09	21.17	412JHH
		24	18-27	滚珠	3.6	14	46	28 AWG 12.2" 引线	381-1126-ND	34.31	26.28	24.09	21.17	414JHH
	60 x 25	12	8-15	滚珠	.53	12.4	22	22 AWG 12.2" 引线	381-2266-ND	27.14	20.79	19.06	16.75	622L
			8-15	滚珠	1.9	23.5	36	22 AWG 12.2" 引线	381-2267-ND	35.72	27.36	25.08	22.04	622N
			8-15	滚珠	2.3	27.1	39	22 AWG 12.2" 引线	381-2264-ND	28.67	21.96	20.13	17.69	622H
			8-15	滚珠	3.5	33	43	22 AWG 12.2" 引线	381-2265-ND	28.67	21.96	20.13	17.69	622HH
			18-28	滚珠	1	12.4	22	22 AWG 12.2" 引线	381-2270-ND	27.14	20.79	19.06	16.75	624L
		24	18-28	滚珠	1.5	17.7	29	22 AWG 12.2" 引线	381-2271-ND	27.14	20.79	19.06	16.75	624M
			18-28	滚珠	2.2	23.5	36	22 AWG 12.2" 引线	381-2272-ND	27.14	20.79	19.06	16.75	624N
			18-28	滚珠	2.3	27.1	39	22 AWG 12.2" 引线	381-2268-ND	28.67	21.96	20.13	17.69	624H
			18-28	滚珠	3.6	33	43	22 AWG 12.2" 引线	381-2269-ND	28.67	21.96	20.13	17.69	624HH
			18-28	滚珠	3.6	33	43	22 AWG 12.2" 引线	381-2269-ND	28.67	21.96	20.13	17.69	624HH
	60 x 32	12	7-13.6	滚珠	7.7	41.1	53	24 AWG 12.2" 引线	381-2282-ND	37.13	28.44	26.07	22.91	612JH
		24	14-26.4	滚珠	7.7	41.1	53	24 AWG 12.2" 引线	381-2283-ND	37.13	28.44	26.07	22.91	614JH
	70 x 15	12	8-13.8	套管	1.7	26	36	28 AWG 12.2" 引线	381-1128-ND	35.72	27.36	25.08	22.04	712F
		24	12-30	套管	1.7	26	36	28 AWG 12.2" 引线	381-1127-ND	35.72	27.36	25.08	22.04	714F

请注意：可根据要求提供专用风扇线缆组件。 \* 要求配接外壳连接器 H10117 和触点 H10119 ◆符合 RoHS 规范要求

(转下页)

全部产品均以美元计价。 免费电话：10800-1527031 (China Telecom - 中国电讯) — 10800-8527031 (CNCG - 中国网通)

2292 (CN082-09)

digikey.com.cn — 电话：(852) 3104 0500 — 传真：(852) 3104 0686

ebmpapst 风扇 (接上页)

图	尺寸 (mm)	电压	电压范围	轴承	瓦	值为0时的CFM	dBA	瓦	引线	Digi-Key 零件编号	单价				ebmpapst Ind. 零件编号
											1	25	50	100	
1	80 x 25	12	7-15	滚珠	0.8	21	21	24 AWG 12.2" 引线	381-1101-ND	23.62	18.09	16.59	14.58	8412L	
			7-15	滚珠	1.4	27	29	24 AWG 12.2" 引线	381-1049-ND	23.62	18.09	16.59	14.58	8412M	
			7-15	滚珠	2.4	33	35	24 AWG 12.2" 引线	381-1010-ND	23.62	18.09	16.59	14.58	8412	
		24	12-28	滚珠	1.4	27	29	24 AWG 12.2" 引线	381-1050-ND	23.62	18.09	16.59	14.58	8414M	
			12-28	滚珠	2.4	33	35	24 AWG 12.2" 引线	381-1011-ND	23.62	18.09	16.59	14.58	8414	
			6-15	滚珠	1.8	28	34	22 AWG 12.2" 引线	381-1048-ND	31.02	23.76	21.78	19.14	8312M	
	80 x 32	12	6-15	滚珠	2.2	32	36	22 AWG 12.2" 引线	381-1008-ND	31.02	23.76	21.78	19.14	8312	
			6-15	滚珠	4	39	43	22 AWG 12.2" 引线	381-1133-ND	40.66	31.14	28.55	25.09	8312HL	
			36-56	滚珠	2.6	32	36	22 AWG 12.2" 引线	381-1077-ND	31.02	23.76	21.78	19.14	8318	
	80 x 38	12	7-13.8	滚珠	10	77.7	55	24 AWG 12.2" 引线	381-2273-ND	42.65	32.67	29.95	26.32	8212JN	
			8-16	滚珠	3	35	39	24 AWG 12.2" 引线	381-1100-ND	60.20	52.02	47.85	40.64	8112K	
		24	18-26.4	滚珠	10	77.7	55	24 AWG 12.2" 引线	381-2274-ND	42.65	32.67	29.95	26.32	8214JN	
			18-30	滚珠	3	35	39	22 AWG 12.2" 引线	381-1047-ND	89.07	68.22	62.54	54.96	8124K	
	92 x 25	12	7-15	滚珠	1.3	36	27	24 AWG 12.2" 引线	381-1080-ND	24.56	18.81	17.25	15.16	3412L	
			7-15	滚珠	1.8	42	32	24 AWG 12.2" 引线	381-1012-ND	24.56	18.81	17.25	15.16	3412M	
			12-28	滚珠	2.6	49	36	22 AWG 12.2" 引线	381-1001-ND	24.56	18.81	17.25	15.16	3414	
	92 x 32	12	6-15	滚珠	2.4	47	37	22 AWG 12.2" 引线	381-1073-ND	31.26	23.94	21.95	19.29	3312	
		24	12-28	滚珠	2.4	47	37	22 AWG 12.2" 引线	381-1074-ND	31.26	23.94	21.95	19.29	3314	
	119 x 25	12	7-14	滚珠	3.2	82	38	22 AWG 12.2" 引线	381-1024-ND	29.85	22.86	20.96	18.42	4412FM	
		24	12-28	滚珠	3.2	82	38	22 AWG 12.2" 引线	381-1025-ND	31.26	23.94	21.95	19.29	4414FM	
	119 x 32	12	6-15	滚珠	2.6	82	39	22 AWG 12.2" 引线	381-1021-ND	32.20	24.66	22.61	19.87	4312M	
			6-15	滚珠	5	100	45	22 AWG 12.2" 引线	381-1002-ND	32.20	24.66	22.61	19.87	4312	
			6-15	滚珠	5	100.1	45	22 AWG 12.2" 引线	381-2263-ND	34.31	26.28	24.09	21.17	4312/2	
		24	12-28	滚珠	2.6	82	39	22 AWG 12.2" 引线	381-1023-ND	32.20	24.66	22.61	19.87	4314M	
			12-28	滚珠	5	100	45	22 AWG 12.2" 引线	381-1003-ND	32.20	24.66	22.61	19.87	4314	
			36-53	滚珠	5	100	45	22 AWG 12.2" 引线	381-1004-ND	35.72	27.36	25.08	22.04	4318	
	119 x 38	12	7-14.5	滚珠	1.2	51	29	22 AWG 12.2" 引线	381-1016-ND	—	32.49	—	—	4212L	
			7-14.5	滚珠	2.2	75	38	22 AWG 12.2" 引线	381-1017-ND	—	32.49	—	—	4212M	
			7-15	滚珠	4.5	106	49	0.110" x 0.02" 端子	381-1014-ND	60.63	46.44	42.57	37.41	4182NX	
			7-14.5	滚珠	5.3	108	49	22 AWG 12.2" 引线	381-1084-ND	42.42	32.49	29.79	26.18	4212H	
			7-15	滚珠	21	162	60	22 AWG 12.2" 引线	381-1142-ND	168.14	128.79	118.06	103.75	DV4112/2NP-3021	
			9-15	滚珠	21	161.9	60	22 AWG 12.2" 引线	381-2275-ND	101.10	88.47	80.88	70.77	DV4112N	
		24	12-28	滚珠	5.3	108	49	22 AWG 12.2" 引线	381-1085-ND	42.42	32.49	29.79	26.18	4214H	
			12-29	滚珠	4.5	106	49	0.110" x 0.02" 端子	381-1015-ND	53.35	40.86	37.46	32.92	4184NX	
			12-25	滚珠	11	140	59	22 AWG 12.2" 引线	381-1139-ND	—	66.33	—	—	4114NXH	
			12-25	滚珠	11	140	59	0.110" x 0.02" 端子	381-1134-ND	74.14	56.79	52.06	45.75	4184NXH	
			16-30	滚珠	19.5	182.4	65	22 AWG 12.2" 引线	381-1161-ND	88.83	68.04	62.37	54.81	4114NH3	
			16-30	滚珠	21	161.9	60	22 AWG 12.2" 引线	381-2276-ND	77.00	67.38	61.60	53.90	DV4114N	
	48	36-56	滚珠	5.6	108	49	0.110" x 0.02" 端子	381-1087-ND	46.88	35.91	32.92	28.93	4298H		
		36-56	滚珠	16	157	63	22 AWG 10.6" 引线	381-1138-ND	126.31	96.75	88.69	77.94	W1G110-AG07-06		
		36-60	滚珠	21	161.9	60	22 AWG 12.2" 引线	381-2277-ND	101.10	88.47	80.88	70.77	DV4118N		
		36-56	滚珠	19.5	182.4	65	22 AWG 12.2" 引线	381-1162-ND	90.59	69.39	63.61	55.90	4118N/2H3		
		8-16	滚珠	4.5	118	44	0.110" x 0.02" 端子	381-1115-ND	81.31	62.28	57.09	50.17	W2G115-AD15-13		
		7-14	滚珠	6	127	46	22 AWG 12.2" 引线	381-1131-ND	49.12	37.62	34.49	30.31	5212NN		
	127 x 38	12	9-15	滚珠	21	158.9	56	22 AWG 12.2" 引线	381-2278-ND	103.70	90.74	82.96	72.59	DV5212N	
			12-28	滚珠	6	127	46	22 AWG 12.2" 引线	381-1132-ND	49.12	37.62	34.49	30.31	5214NN	
			16-30	滚珠	21	158.9	56	22 AWG 12.2" 引线	381-2279-ND	103.70	90.74	82.96	72.59	DV5214N	
		24	12-28	滚珠	12	160	52	0.110" x 0.02" 端子	381-1068-ND	87.19	66.78	61.22	53.80	W2G115-AG71-12	
16-28			滚珠	12	160	52	22 AWG 12.2" 引线	381-2280-ND	79.00	69.13	63.20	55.30	DV5218N		
43-53			滚珠	22	159	56	22 AWG 12.2" 引线	381-1147-ND	—	129.02	—	—	DV5218/2NP-40182		
48		12-28	滚珠	18	241	57	0.118" x 0.02" 端子	381-1005-ND	85.78	65.70	60.23	52.93	6424		
		12-28	滚珠	26	283	61	0.118" x 0.02" 端子	381-1043-ND	99.52	76.23	69.88	61.41	6224NH		
		12-28	滚珠	26	283	63	0.118" x 0.02" 端子	381-1046-ND	135.01	103.41	94.80	83.31	6424H		
		16-30	滚珠	37	318	63	22 AWG 12.2" 引线	381-1156-ND	145.70	127.49	116.56	101.99	DV6224		
		28-60	滚珠	17	241	55	0.118" x 0.02" 端子	381-1045-ND	112.57	86.22	79.04	69.46	6248N		
		40-60	滚珠	37	318	63	22 AWG 12.2" 引线	381-1157-ND	145.70	127.49	116.56	101.99	DV6248		
DC Flatpak 鼓风机															
4	76 x 27	12	8-13.5	滚珠	5	16.5	51	22 AWG 12.2" 引线	381-1148-ND	40.54	31.05	28.47	25.02	RL48-19/12	
		24	18-26.4	滚珠	5	16.5	51	22 AWG 12.2" 引线	381-1149-ND	45.71	35.01	32.10	28.21	RL48-19/14	
	97 x 93.5 x 33	12	8-12	滚珠	12.5	32.4	62	26 AWG 12.2" 引线	381-1150-ND	49.12	37.62	34.49	30.31	RL65-21/12/2	
		12	7-15	滚珠	5	24	58	22 AWG 12.2" 引线	381-1059-ND	61.92	47.43	43.48	38.21	RL90-18/12N	
	121 x 37	24	12-28	滚珠	5	24	58	22 AWG 12.2" 引线	381-1060-ND	61.92	47.43	43.48	38.21	RL90-18/14N	
		12	8-15	滚珠	8	37.7	60	22 AWG 12.2" 引线	381-1151-ND	72.20	63.18	57.76	50.54	RLF100-11/12	
127 x 25	24	6-30	滚珠	8	37.7	60	22 AWG 12.2" 引线	381-1152-ND	84.90	74.29	67.92	59.43	RLF100-11/14		

请注意: 可根据要求提供专用风扇线缆组件。 \* 要求配接外壳连接器 H10117 和触点 H10119 ◆ 符合 RoHS 规范要求

图	尺寸 (mm)	电压	电压范围	输入功率	值为0时的CFM	dBA	瓦	叶轮材料	Digi-Key 零件编号	1	25	50	100	ebmpapst Ind. 零件编号	
DC 电动叶轮															
5	102 x 52	12	11-13	90	69	13.5	塑料	381-1129-ND	117.15	89.73	82.26	72.29	RER101-36/12/12P		

图	尺寸 (mm)	电压	输入功率	值为0时的CFM	dBA	叶轮尺寸 (英寸) (mm)	电容器	叶轮材料	Digi-Key 零件编号	1	25	50	100	ebmpapst Ind. 零件编号	
AC 向后弯曲式电动叶轮 - 符合 RoHS 规范要求															
5	220 x 71	115	96	500	71	8.66" (220) x 2.8" (71)	10	塑料	381-1110-ND	137.48	105.30	96.53	84.83	R2E220-AA44-23	
		230	100	530	71	8.66" (220) x 2.8" (71)	2	塑料	381-1109-ND	104.81	80.28	73.59	64.67	R2E220-AA40-23	

图	尺寸 (mm)	电压	输入功率	值为0时的CFM	dBA	叶轮尺寸 (英寸) (mm)	叶轮材料	Digi-Key 零件编号	1	25	50	100	ebmpapst Ind. 零件编号		
DC 向后弯曲式电动叶轮 - 符合 RoHS 规范要求															
5	133 x 91	24	28	212	63	5.25" (133) x 2.39" (60.6)	塑料	381-1154-ND	190.90	167.04	152.72	133.63	R1G133-AA17-02		
	175 x 69	48	36	330	65	6.9" (175) x 2.72" (69)	塑料	381-1159-ND	150.80	131.95	120.64	105.56	R1G175-AB41-02		

全部产品均以美元计价。 免费电话: 10800-1527031 (China Telecom - 中国电信) — 10800-8527031 (CNCG - 中国网通)

digikkey.com.cn — 电话: (852) 3104 0500 — 传真: (852) 3104 0686

(CN082-09) 2293

# DELTA DC 轴向风扇和鼓风机

产品范围广, 包括 25mm 至 172mm 的轴流式风机和 30mm 至 159mm 的鼓风机。  
 特点: • 独特的叶片设计 • 无刷 • 通过 TS16949 认证 • 通过 ISO-9001 认证 • 滚珠轴承 • 引线



图	尺寸 (mm)	额定电压	工作温度范围	额定电流 (A)	额定输入功率 (W)	速度 (RPM)	CFM	噪音 (Db)	传感器	Digi-Key 零件编号	1	10	100	Delta 零件编号	护指罩	单价
轴向风扇																
1	25 x 25 x 10	12	7.0 - 13.2	.080	0.96	13000	2.40	28.0	—	603-1129-ND	12.72	8.40	6.96	AFB02512HHA-A	—	—
	35 x 35 x 10	12	9.5 - 13.8	.090	1.08	7000	5.50	22.0	—	603-1128-ND	12.72	8.40	6.96	AFB03512HA-A	CR378-ND	.66
	40 x 40 x 10	12	7.0 - 13.8	.060	.72	5000	5.90	24.5	—	603-1002-ND	9.78	7.44	6.38	EFB0412MA	CR230-ND	.65
		12	7.0 - 13.8	.080	.96	6000	6.92	28.5	—	603-1003-ND	9.78	7.44	6.38	EFB0412HA	CR230-ND	.65
		12	7.0 - 13.8	.100	1.20	7000	8.09	33.0	—	603-1004-ND	11.26	7.44	6.17	EFB0412HHA	CR230-ND	.65
		12	7.0 - 13.8	.130	1.56	8300	11.48	32.0	—	603-1005-ND	11.81	9.09	7.62	AFB0412HHB	CR230-ND	.65
	40 x 40 x 15	12	7.0 - 13.8	.250	3.00	11000	14.83	41.5	—	603-1006-ND	11.81	9.09	7.62	AFB0412SHB	CR230-ND	.65
		5	4.5 - 5.5	.250	1.25	7600	8.54	28.5	—	603-1007-ND	10.93	8.32	7.13	EFB0405HD	CR230-ND	.65
	40 x 40 x 20	5	4.5 - 5.5	.320	1.60	9000	10.10	32.5	Tac	603-1008-ND	13.25	8.75	7.25	EFB0405VHD-F00	CR230-ND	.65
		12	7.0 - 13.8	.080	0.96	7600	8.54	28.5	—	603-1009-ND	12.59	8.32	6.89	EFB0412HD	CR230-ND	.65
		12	7.0 - 13.8	.120	1.44	9000	10.10	32.5	—	603-1010-ND	12.59	8.32	6.89	EFB0412VHD	CR230-ND	.65
		24	14.0 - 27.6	.040	0.96	5000	5.54	22.0	—	603-1011-ND	10.93	8.32	7.13	EFB0424LD	CR230-ND	.65
		12	4.5 - 13.8	.070	0.84	6500	10.59	32.1	Tac	603-1012-ND	16.43	10.85	8.99	FFB0412HN-F00	CR230-ND	.65
	40 x 40 x 28	12	4.0 - 13.8	.500	6.00	13000	24.00	51.5	Tac	603-1013-ND	18.82	12.43	10.30	FFB0412SHN-F00	CR230-ND	.65
		12	4.5 - 13.2	.160	1.92	9500	15.79	41.9	—	603-1014-ND	13.39	10.30	8.63	FFB0412VHN	CR230-ND	.65
		12	4.5 - 13.2	.160	1.92	9500	15.79	41.9	—	603-1015-ND	16.43	10.85	8.99	FFB0412VHN-B	CR230-ND	.65
		12	4.5 - 13.2	.160	1.92	9500	15.79	41.9	Tac	603-1016-ND	16.43	10.85	8.99	FFB0412VHN-F00	CR230-ND	.65
		12	4.5 - 13.2	.160	1.92	9500	15.79	41.9	—	603-1017-ND	16.43	10.85	8.99	FFB0412VHN-R00	CR230-ND	.65
		24	14.0 - 26.4	.100	2.40	9500	15.79	41.9	锁定转子	603-1018-ND	15.77	10.42	8.63	FFB0424VHN	CR230-ND	.65
		12	7.0 - 13.2	.850	10.20	12000	24.00	60.0	Tac	603-1019-ND	31.14	20.57	17.04	GFB0412SHG-F00	CR230-ND	.65
2	40 x 40 x 56	12	7.0 - 13.2	1.25	15.00	15000	27.30	59.5	Tac	603-1020-ND	31.14	20.57	17.04	GFB0412EHS-F00	CR230-ND	.65
1	45 x 45 x 10	12	7.0 - 13.8	.110	1.32	5000	9.85	30.0	—	603-1021-ND	11.81	9.09	7.62	AFB04512MA	—	—
	50 x 50 x 10	5	4.5 - 5.5	.130	0.65	4500	9.21	25.0	Tac	603-1022-ND	11.93	7.88	6.53	EFB0505MA-F00	CR379-ND	.86
		12	7.0 - 13.8	.100	1.20	5500	11.4	30.0	—	603-1023-ND	9.78	7.44	6.38	EFB0512HA	CR379-ND	.86
	50 x 50 x 15	12	7.0 - 13.8	.100	1.20	5600	14.13	32.0	—	603-1024-ND	13.91	9.19	7.62	AFB0512HB	CR379-ND	.86
	50 x 50 x 20	12	7.0 - 13.8	.160	1.92	7000	20.30	40.5	—	603-1025-ND	13.91	9.19	7.62	AFB0512VHD	CR379-ND	.86
	60 x 60 x 10	12	7.0 - 13.8	.180	2.16	4800	21.19	36.5	—	603-1026-ND	12.59	8.32	6.89	EFB0612HHA	CR221-ND	.68
	60 x 60 x 15	5	4.0 - 6.0	.300	1.50	4000	15.36	32.0	—	603-1027-ND	13.91	9.19	7.62	AFB0605HB	CR221-ND	.68
		24	14.0 - 27.6	.080	1.92	4000	15.36	32.0	—	603-1028-ND	13.91	9.19	7.62	AFB0624HB	CR221-ND	.68
	60 x 60 x 20	12	7.0 - 13.8	.150	1.80	4400	18.36	31.0	—	603-1029-ND	11.81	9.09	7.62	AFB0612HHD	CR221-ND	.68
	60 x 60 x 25.4	12	4.0 - 13.8	.080	0.96	3100	16.81	26.5	—	603-1030-ND	15.50	10.24	8.49	AFB0612L-A	CR221-ND	.68
		12	4.0 - 13.8	.140	1.68	4250	23.38	34.0	—	603-1031-ND	13.16	10.13	8.49	AFB0612H-A	CR221-ND	.68
		12	4.0 - 13.8	.170	2.04	5000	27.55	40.0	—	603-1032-ND	11.81	9.09	7.62	AFB0612HH-A	CR221-ND	.68
		12	4.0 - 13.8	.270	3.24	6000	34.15	44.5	Tac	603-1033-ND	16.83	11.12	9.21	AFB0612SH-ABF00	CR221-ND	.68
		12	4.0 - 13.8	.270	3.24	6000	34.15	44.5	Tac	603-1034-ND	16.17	10.68	8.85	AFB0612SH-AF00	CR221-ND	.68
		12	4.0 - 13.8	.380	4.56	6800	38.35	46.5	Tac	603-1035-ND	16.83	11.12	9.21	AFB0612EH-ABF00	CR221-ND	.68
		24	14.0 - 27.6	.090	2.16	4250	23.38	34.0	—	603-1036-ND	15.50	10.24	8.49	AFB0624H-A	CR221-ND	.68
		24	14.0 - 27.6	.110	2.64	5000	27.55	40.0	—	603-1037-ND	15.50	10.24	8.49	AFB0624HH-A	CR221-ND	.68
	60 x 60 x 38	12	4.5 - 13.8	.340	4.08	6000	36.73	46.5	—	603-1038-ND	18.15	11.99	9.94	FFB0612VHE	CR221-ND	.68
12		4.5 - 13.8	.550	6.60	7000	43.44	50.5	—	603-1039-ND	15.07	11.86	9.94	FFB0612SHE	CR221-ND	.68	
12		4.5 - 13.8	.800	9.60	8000	50.15	54.5	—	603-1040-ND	18.15	11.99	9.94	FFB0612EHE	CR221-ND	.68	
12		7.0 - 13.8	.680	8.16	9000	49.54	54.0	—	603-1041-ND	20.41	13.48	11.17	AFB0612VHE-A	CR221-ND	.68	
2	60 x 60 x 50.8	12	7.0 - 13.8	.430	5.16	5000	32.14	50.5	—	603-1042-ND	24.70	20.14	17.29	GFB0612HHG	CR221-ND	.68
1	70 x 70 x 20	12	5.0 - 13.8	.250	3.00	4400	40.43	40.5	—	603-1043-ND	11.81	9.09	7.62	AFB0712HHD	—	—
		12	5.0 - 12.6	.440	5.28	5500	51.97	47.5	—	603-1044-ND	13.91	9.19	7.62	AFB0712VH-A	—	—
	70 x 70 x 25.4	12	5.0 - 13.8	.650	7.80	6300	61.05	50.5	—	603-1045-ND	16.96	11.20	9.28	AFB0712SH-AB	—	—
		24	14.0 - 26.4	.090	2.16	3100	28.85	31.5	—	603-1046-ND	13.16	10.13	8.49	AFB0724M-A	—	—
	80 x 80 x 15	12	7.0 - 13.8	.190	2.28	3700	39.20	39.5	Tac	603-1047-ND	14.58	9.63	7.98	AFB0812VHB-F00	CR180-ND	.93
		12	7.0 - 13.8	.220	2.64	4000	48.20	41.0	—	603-1048-ND	13.91	9.19	7.62	AFB0812SHD	CR180-ND	.93
	80 x 80 x 25.4	5	4.5 - 5.5	.430	2.15	3000	35.31	31.0	—	603-1049-ND	13.91	9.19	7.62	AFB0805H	CR180-ND	.93
		12	7.0 - 13.8	.160	1.92	3000	35.31	31.0	—	603-1050-ND	13.91	9.19	7.62	AFB0812H	CR180-ND	.93
		12	7.0 - 13.8	.200	2.40	3250	37.43	34.0	—	603-1051-ND	13.91	9.19	7.62	AFB0812HH	CR180-ND	.93
		12	7.0 - 13.8	.200	2.40	3250	37.43	34.0	—	603-1051-ND	13.91	9.19	7.62	AFB0812HH	CR180-ND	.93

(转下页)

全部产品均以美元计价。 免费电话: 10800-1527031 (China Telecom - 中国电讯) — 10800-8527031 (CNCG - 中国网通)

2294 (CN082-09)

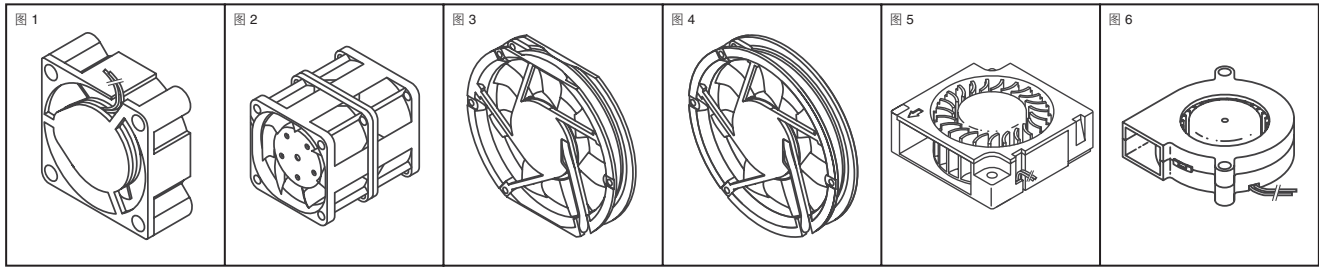
digikey.com.cn — 电话: (852) 3104 0500 — 传真: (852) 3104 0686



DC 轴向风扇和鼓风机 (接上页)



图	尺寸 (mm)	额定电压	工作温度范围	额定电流 (A)	额定输入功率 (W)	速度 (RPM)	CFM	噪音 (Db)	传感器	Digi-Key 零件编号	单价			Delta 零件编号	护罩	单价		
											10	100	1000					
1	80 x 80 x 25.4	12	7.0 ~ 13.8	.200	2.40	3250	37.43	34.0	Tac	603-1052-ND	14.58	9.63	7.98	AFB0812HH-F00	CR180-ND	.93		
		12	7.0 ~ 13.2	.260	3.12	3500	47.22	41.7	—	603-1053-ND	19.01	14.94	12.90	FFB0812HH	CR180-ND	.93		
		12	7.0 ~ 13.8	.340	4.08	4000	46.62	40.0	Tac	603-1054-ND	14.58	9.63	7.98	AFB0812SH-F00	CR180-ND	.93		
		12	7.0 ~ 13.2	.500	6.00	4500	67.02	48.6	—	603-1055-ND	19.01	14.94	12.90	FFB0812SH	CR180-ND	.93		
	80 x 80 x 38	12	7.0 ~ 13.8	.380	4.56	4200	57.21	44.5	—	603-1056-ND	18.15	11.99	9.94	FFB0812VHE	CR180-ND	.93		
		12	7.0 ~ 13.8	.580	6.96	4900	68.51	48.5	—	603-1057-ND	18.15	11.99	9.94	FFB0812SHE	CR180-ND	.93		
		12	7.0 ~ 13.8	.900	10.80	5700	80.16	52.5	Tac	603-1058-ND	18.82	12.43	10.30	FFB0812EHE-F00	CR180-ND	.93		
		12	7.0 ~ 13.2	1.15	13.80	6600	89.95	59.8	—	603-1059-ND	22.22	17.48	14.65	FFB0812GHE	CR180-ND	.93		
		12	7.0 ~ 13.2	1.50	18.00	7500	102.02	62.2	—	603-1060-ND	20.20	16.47	14.14	FFB0812UHE	CR180-ND	.93		
		12	7.0 ~ 13.2	2.75	33.00	9000	132.56	65.0	—	603-1061-ND	26.80	21.85	18.76	FFB0812DHE	CR180-ND	.93		
		2	80 x 80 x 50.8	12	7.0 ~ 13.2	.730	8.76	4200	68.58	53.0	Tac	603-1062-ND	33.39	22.05	18.27	GFB0812SHG-F00	CR180-ND	.93
		1	92 x 92 x 20	24	14.0 ~ 27.6	.100	2.40	2700	54.60	35.0	—	603-1063-ND	11.81	9.09	7.62	AFB0924HD	CR220-ND	.77
12	7.0 ~ 13.8			.160	1.92	2850	51.21	34.0	—	603-1064-ND	13.91	9.19	7.62	AFB0912H	CR220-ND	.77		
12	7.0 ~ 13.8			.250	3.00	3200	57.92	38.0	—	603-1065-ND	13.91	9.19	7.62	AFB0912HH	CR220-ND	.77		
12	7.0 ~ 13.8			.600	7.20	3700	81.97	48.2	—	603-1066-ND	15.07	11.86	9.94	FFB0912VH	CR220-ND	.77		
12	7.0 ~ 13.8			.400	4.80	3800	67.80	45.0	—	603-1067-ND	11.81	9.09	7.62	AFB0912VH	CR220-ND	.77		
24	14.0 ~ 27.6			.080	1.92	2450	43.79	30.0	—	603-1068-ND	11.81	9.09	7.62	AFB0924M	CR220-ND	.77		
92 x 92 x 38	24		14.0 ~ 27.6	.100	2.40	2850	51.21	34.0	—	603-1069-ND	13.91	9.19	7.62	AFB0924H	CR220-ND	.77		
	24		14.0 ~ 27.6	.220	5.28	3800	67.80	45.0	—	603-1070-ND	13.91	9.19	7.62	AFB0924VH	CR220-ND	.77		
	12		7.0 ~ 13.2	1.22	14.64	6000	129.31	60.5	—	603-1071-ND	27.30	22.25	19.11	FFB0912GHE	CR220-ND	.77		
	24		14.0 ~ 27.6	.280	6.72	3800	85.46	47.5	—	603-1072-ND	18.95	12.52	10.37	FFB0924VHE	CR220-ND	.77		
	48		28.0 ~ 53.0	.200	9.60	4400	100.29	52.5	—	603-1073-ND	24.12	15.93	13.20	FFB0948SHE	CR220-ND	.77		
	100 x 100 x 38		12	7.0 ~ 12.6	2.20	26.40	5000	143.09	62.0	—	603-1074-ND	31.93	21.09	17.48	FFB1012EHE	—	—	
1	120 x 120 x 25.4		12	7.0 ~ 13.8	.230	2.76	2500	82.67	38.5	—	603-1075-ND	14.52	11.42	9.57	AFB1212H	CR210-ND	1.72	
			12	7.0 ~ 13.8	.330	3.96	2800	95.14	41.5	—	603-1076-ND	17.49	11.55	9.57	AFB1212HH	CR210-ND	1.72	
			24	14.0 ~ 27.6	.280	6.72	3400	113.11	46.5	—	603-1077-ND	18.29	12.08	10.01	AFB1224SH	CR210-ND	1.72	
	120 x 120 x 38		12	4.0 ~ 13.2	.600	7.20	3200	129.96	48.0	Tac	603-1078-ND	20.27	13.39	11.10	AFB1212VHE-F00	CR210-ND	1.72	
			12	7.0 ~ 13.2	1.00	12.00	3200	151.85	53.0	—	603-1080-ND	31.93	21.09	17.48	FFB1212VHE	CR210-ND	1.72	
			12	7.0 ~ 13.2	1.50	18.00	3600	170.92	56.5	Tac	603-1081-ND	32.60	21.53	17.84	FFB1212SHE-F00	CR210-ND	1.72	
			12	4.0 ~ 13.2	1.05	12.60	3700	151.85	53.0	—	603-1082-ND	16.28	12.58	10.73	AFB1212SHE	CR210-ND	1.72	
			12	7.0 ~ 13.2	2.00	24.00	4000	190.00	59.0	Tac	603-1083-ND	32.60	21.53	17.84	FFB1212EHE-F00	CR210-ND	1.72	
			12	8.0 ~ 13.2	2.70	32.40	4800	217.80	64.0	—	603-1084-ND	42.00	27.74	22.99	FFB1212GHE	CR210-ND	1.72	
			24	7.0 ~ 27.6	.240	5.76	2600	105.94	41.0	—	603-1085-ND	16.94	13.09	10.98	AFB1224HE	CR210-ND	1.72	
			24	7.0 ~ 27.6	.380	9.12	3200	129.96	48.0	—	603-1086-ND	16.94	13.09	10.98	AFB1224VHE	CR210-ND	1.72	
			24	14.0 ~ 26.4	1.00	24.00	4000	190.00	59.0	—	603-1088-ND	33.52	22.14	18.35	FFB1224EHE	CR210-ND	1.72	
48	28.0 ~ 53.0		.500	24.00	4000	190.00	59.0	Tac	603-1089-ND	38.29	25.29	20.96	FFB1248EHE-F00	CR210-ND	1.72			
48	32.0 ~ 80.0		.910	43.68	5300	223.22	68.0	—	603-1090-ND	54.00	45.00	40.50	FHB1248UHE	CR210-ND	1.72			
2	120 x 120 x 50.8		12	7.0 ~ 13.2	2.82	33.84	3400	184.45	65.0	—	603-1091-ND	63.60	42.00	34.80	GFB1212VHG	CR210-ND	1.72	
			24	14.0 ~ 26.4	1.80	43.20	3700	203.41	67.6	—	603-1092-ND	63.60	42.00	34.80	GFB1224SHG	CR210-ND	1.72	
120 x 120 x 76.2	12		7.0 ~ 13.2	2.65	31.80	3550	220.29	59.0	—	603-1093-ND	43.70	35.65	31.63	GFB1212VHW	CR210-ND	1.72		
1	127 x 127 x 38		12	7.0 ~ 13.2	1.85	22.20	3450	180.00	56.5	—	603-1094-ND	31.20	25.60	22.40	FFB1312SHE	CR200-ND	2.51	
			12	8.5 ~ 13.2	2.74	32.88	3850	200.02	59.5	—	603-1095-ND	31.20	25.60	22.40	FFB1312EHE	CR200-ND	2.51	
			24	14.0 ~ 26.4	.840	20.16	3450	180.00	56.5	—	603-1096-ND	45.71	30.19	25.02	FFB1324SHE-B	CR200-ND	2.51	
3	140 x 140 x 50.8		48	28.0 ~ 53.0	.770	36.96	3600	273.09	61.7	Tac	603-1097-ND	74.86	49.44	40.97	FFB1448SHG-F00	CR196-ND	3.02	
			12	6.0 ~ 14.0	.980	11.76	3000	202.54	52.0	—	603-1126-ND	51.57	42.98	38.68	AFB1512H-A	CR196-ND	3.02	
			12	6.0 ~ 14.0	1.17	14.04	3200	214.85	53.5	—	603-1099-ND	51.57	42.98	38.68	AFB1512HH-A	CR196-ND	3.02	
			24	12.0 ~ 30.0	.310	7.44	2400	160.77	46.0	—	603-1125-ND	75.92	50.14	41.55	AFB1524L-A	CR196-ND	3.02	
	48	32.0 ~ 80.0	.520	24.96	4000	271.05	61.0	—	603-1101-ND	108.73	71.81	59.50	AHB1548EH	CR196-ND	3.02			
	172 x 150 x 50.8	24	12.0 ~ 28.0	.560	13.44	3350	251.79	55.0	—	603-1102-ND	68.9	45.50	39.50	FFB1524HG	CR196-ND	3.02		
24		12.0 ~ 28.0	.970	23.28	4000	302.29	60.0	—	603-1103-ND	49.40	40.30	35.75	EFB1524VHG	CR196-ND	3.02			
48		24.0 ~ 60.0	.310	14.88	3350	251.79	55.0	Tac	603-1104-ND	72.21	47.69	39.52	EFB1548HG-F00	CR196-ND	3.02			
4	172 x 25.4	12	6.0 ~ 14.0	.980	11.76	3000	202.54	52.0	—	603-1105-ND	61.79	50.41	44.72	AFB1712H-A	CR206-ND	2.84		
		12	6.0 ~ 14.0	1.17	14.04	3200	214.85	53.5	—	603-1106-ND	86.18	56.91	47.16	AFB1712HH-A	CR206-ND	2.84		
		24	12.0 ~ 30.0	.310	7.44	2400	160.77	46.0	—	603-1107-ND	61.79	50.41	44.72	AFB1724L-A	CR206-ND	2.84		
		48	24.0 ~ 60.0	.270	12.96	3000	202.54	52.0	—	603-1127-ND	90.26	59.61	49.39	AFB1748H-A	CR206-ND	2.84		
172 x 50.8	12	8.0 ~ 14.0	1.79	21.48	3700	279.69	55.0	—	603-1109-ND	66.25	43.75	36.25	EFB1712HHG	CR206-ND	2.84			
	24	12.0 ~ 28.0	1.17	28.08	4300	325.00	59.0	Tac	603-1130-ND	48.56	40.17	36.10	EFB1724SHG-F00	CR206-ND	2.84			
	48	26.0 ~ 54.0	1.90	91.20	4600	432.77	72.0	—	603-1111-ND	52.20	43.50	39.15	FFB1748VHG	CR206-ND	2.84			
鼓风机																		
5	30 x 30 x 10	12	7.0 ~ 13.2	.070	0.84	7500	1.45	29.0	—	603-1112-ND	11.48	8.83	7.40	BFB0312HA	—	—		
		40 x 40 x 10	5	4.0 ~ 6.0	.220	1.10	8500	3.00	34.5	—	603-1113-ND	14.84	9.80	8.12	BFB0405HHA-A	—	—	
6	51 x 51 x 15	12	10.0 ~ 13.8	.160	1.92	5500	3.88	38.0	锁定转子	603-1114-ND	18.15	11.99	9.94	BFB0512H-F00	—	—		
		12	10.0 ~ 13.8	.210	2.52	6000	4.59	45.0	Tac	603-1115-ND	18.15	11.99	9.94	BFB0512HH-F00	—	—		
		24	14.0 ~ 27.6	.110	2.64	6500	4.59	45.0	—	603-1116-ND	17.49	11.55	9.57	BFB0524HH	—	—		
	60 x 60 x 25	12	5.0 ~ 13.8	.180	2.16	3200	6.71	34.0	—	603-1117-ND	12.60	9.69	8.12	BFB0612H	—	—		
	75 x 75 x 30	12	7.0 ~ 13.8	.220	2.64	3900	11.30	38.0	—	603-1118-ND	20.67	13.65	11.31	BFB0712H	—	—		
	97 x 94 x 33	12	4.0 ~ 13.8	.800	9.60	3600	25.43	52.0	Tac	603-1119-ND	24.38	16.10	13.34	BFB1012H-F00	—	—		
		24	7.0 ~ 27.6	.400	9.60	3600	25.43	52.0	Tac	603-1120-ND	24.38	16.10	13.34	BFB1024H-F00	—</			