



## 瞬时触摸开关 KT11 系列

尺寸: mm

图	触动器高度	端子	触点材质	Digi-Key 零件编号	剪切带 单价			Digi-Key 零件编号	带卷		C&K Components 零件编号
					1	25	100		数量	价格	
1	凹槽	J形引线	银	CKN8001CT-ND	1.94	1.68	1.35	—	—	KT11B0JM	
	凹槽	J形引线	银	CKN1831CT-ND	2.35	2.18	2.00	CKN1831TR-ND	1,100	1303.20/M	KT11B0JM34LFS
	.025"	J形引线	银	CKN1835CT-ND	2.56	2.37	2.17	CKN1835TR-ND	1,100	1418.40/M	KT11B1JM34LFS
	.088"	J形引线	银	CKN1864CT-ND	2.61	2.42	2.22	CKN1864TR-ND	1,100	1447.20/M	KT11B2JM34LFS
	.093"	J形引线	银	CKN1842CT-ND	2.43	2.25	2.06	CKN1842TR-ND	1,100	1344.60/M	KT11P2JM34LFS
2	.044"	J形引线	银	CKN1849CT-ND	2.40	2.22	2.04	CKN1849TR-ND	1,100	1330.20/M	KT11P3JM34LFS
	.156"	J形引线	银	CKN1855CT-ND	2.46	2.28	2.09	CKN1855TR-ND	800	1090.08	KT11P4JM34LFS
	凹槽	鸥翼形	银	CKN4072CT-ND	2.26	1.95	1.57	—	—	KT11B0SM	
	凹槽	鸥翼形	银	CKN1834CT-ND	2.73	2.52	2.31	CKN1834TR-ND	1,100	1512.00/M	KT11B0SM34LFS
	.025"	鸥翼形	银	CKN1838CT-ND	2.97	2.74	2.52	CKN1838TR-ND	1,100	1643.40/M	KT11B1SM34LFS
3	.088"	鸥翼形	银	CKN4074CT-ND	2.47	2.13	1.71	—	—	KT11B2SM	
	.093"	鸥翼形	银	CKN1841CT-ND	2.98	2.75	2.52	CKN1841TR-ND	1,100	1648.80/M	KT11B2SM34LFS
	.093"	鸥翼形	银	CKN1848CT-ND	2.78	2.57	2.36	CKN1848TR-ND	1,100	1539.00/M	KT11P2SM34LFS
	.044"	鸥翼形	银	CKN1854CT-ND	2.75	2.54	2.33	CKN1854TR-ND	1,100	1522.80/M	KT11P3SM34LFS
	.156"	鸥翼形	银	CKN1860CT-ND	2.81	2.60	2.38	CKN1860TR-ND	800	1244.16	KT11P4SM34LFS
4	凹槽	鸥翼形	金	CKN1832CT-ND	2.59	2.40	2.20	CKN1832TR-ND	800	1149.12	KT11B0SAM34LFS
	凹槽	鸥翼形	金	CKN1804CT-ND	2.76	2.55	2.34	—	—	KT11B0SAM33	
	凹槽	鸥翼形	金	CKN1833CT-ND	2.76	2.55	2.34	CKN1833TR-ND	800	1224.00	KT11B0SAM35LFG
	.025"	鸥翼形	金	CKN1836CT-ND	2.61	2.42	2.22	CKN1836TR-ND	800	1157.76	KT11B1SAM34LFS
	.025"	鸥翼形	金	CKN1805CT-ND	3.23	2.99	2.74	CKN1805TR-ND	800	1431.20	KT11B1SAM33
5	.025"	鸥翼形	金	CKN1837CT-ND	4.05	3.74	3.43	CKN1837TR-ND	800	1794.24	KT11B1SAM35LFG
	.088"	鸥翼形	金	CKN1839CT-ND	2.64	2.44	2.24	CKN1839TR-ND	800	1169.28	KT11B2SAM34LFS
	.088"	鸥翼形	金	CKN1806CT-ND	2.82	2.61	2.39	—	—	KT11B2SAM33	
	.088"	鸥翼形	金	CKN1840CT-ND	4.05	3.74	3.43	CKN1840TR-ND	800	1794.24	KT11B2SAM35LFG
	压接式	鸥翼形	金	CKN1862CT-ND	2.93	2.70	2.48	CKN1862TR-ND	500	810.00	KT11S1SA3M34LFS
6	.093"	鸥翼形	金	CKN1803CT-ND	2.19	2.02	1.86	—	—	KT11P2SA3M33	
	.093"	鸥翼形	金	CKN1847CT-ND	3.40	3.14	2.88	CKN1847TR-ND	500	941.40	KT11P2SA3M35LFG
	.093"	鸥翼形	银	CKN1562CT-ND	2.19	2.02	1.86	—	—	KT11P2SA3M31	
	.044"	鸥翼形	金	CKN1846CT-ND	3.40	3.14	2.88	CKN1846TR-ND	500	941.40	KT11P2SA3M34LFS
	.044"	鸥翼形	金	CKN1785CT-ND	2.95	2.73	2.50	—	—	KT11P3SA3M33	
7	.044"	鸥翼形	金	CKN1853CT-ND	4.01	3.71	3.40	CKN1853TR-ND	500	1111.50	KT11P3SA3M35LFG
	.156"	鸥翼形	金	CKN1859CT-ND	6.65	6.15	5.63	CKN1859TR-ND	500	1842.30	KT11P4SA3M35LFG
	.093"	鸥翼形	金	CKN1807CT-ND	2.76	2.55	2.34	—	—	KT11P2SA1M33	
	.093"	鸥翼形	金	CKN1843CT-ND	3.47	3.21	2.94	CKN1843TR-ND	800	1536.48	KT11P2SA1M35LFG
	.044"	鸥翼形	金	CKN1850CT-ND	2.59	2.40	2.20	CKN1850TR-ND	800	1149.12	KT11P3SA1M34LFS
8	.044"	鸥翼形	金	CKN1808CT-ND	2.76	2.55	2.34	—	—	KT11P3SA1M33	
	.044"	鸥翼形	金	CKN1851CT-ND	2.76	2.55	2.34	CKN1851TR-ND	800	1224.00	KT11P3SA1M35LFG
	.156"	鸥翼形	金	CKN1856CT-ND	2.64	2.44	2.24	CKN1856TR-ND	800	1169.28	KT11P4SA1M34LFS
	.156"	鸥翼形	金	CKN1857CT-ND	3.40	3.14	2.88	CKN1857TR-ND	800	1506.24	KT11P4SA1M35LFG
	压接式	鸥翼形	金	CKN1861CT-ND	3.62	3.35	3.07	CKN1861TR-ND	600	1204.20	KT11S1SA2M35LFG
9	扣合式	鸥翼形	金	CKN1863CT-ND	3.62	3.35	3.07	CKN1863TR-ND	600	1204.20	KT11S2SA2M35LFG
	.093"	鸥翼形	金	CKN1844CT-ND	2.61	2.42	2.22	CKN1844TR-ND	600	868.32	KT11P2SA2M34LFS
	.093"	鸥翼形	金	CKN1810CT-ND	2.76	2.55	2.34	—	—	KT11P2SA2M33	
	.093"	鸥翼形	金	CKN1845CT-ND	3.64	3.36	3.08	CKN1845TR-ND	600	1209.60	KT11P2SA2M35LFG
	.044"	鸥翼形	金	CKN1802CT-ND	2.76	2.55	2.34	—	—	KT11P3SA2M33	
10	.044"	鸥翼形	金	CKN1852CT-ND	3.23	2.99	2.74	CKN1852TR-ND	3,000	1491.00/M	KT11P3SA2M35LFG
	.156"	鸥翼形	金	CKN1564CT-ND	2.19	2.02	1.86	—	—	KT11P4SA2M33	
	.156"	鸥翼形	金	CKN1858CT-ND	3.49	3.23	2.96	CKN1858TR-ND	600	1159.92	KT11P4SA2M35LFG

符合 RoHS 规范要求

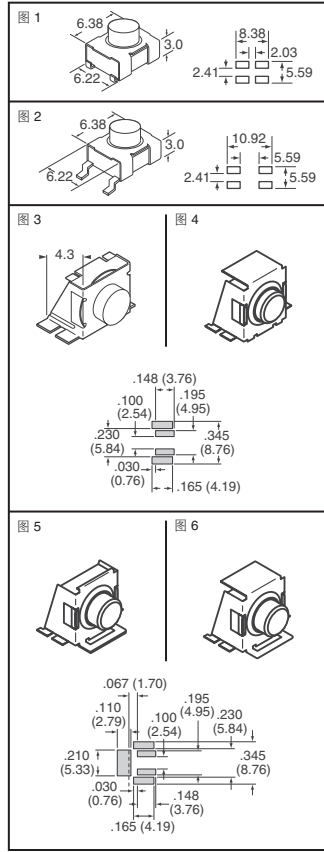

## 密封表面贴装式触摸开关 KSC 系列 - 可清洗, 完全密封 (IP67)

- 电路: SPST-NO • 开关: 最大电压: 32VDC; 最大电流: (银) 50mA, (金) 10mA • 触点电阻: 100mΩ
- 工作温度: 银: -40°C ~ 85°C; 金: -40°C ~ 125°C

尺寸: mm

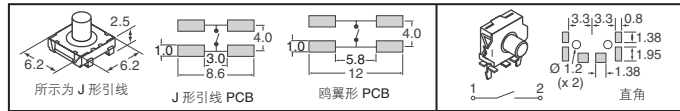

操作力	触动器	端子	触点材质	Digi-Key 零件编号	剪切带 单价			Digi-Key 零件编号	带卷		C&K Components 零件编号
					1	25	100		数量	价格	
160gF	凹槽	鸥翼形	银	401-1749-1-ND	.41	.38	.35	—	—	KSC121GLFS	
300gF	凹槽	鸥翼形	银	401-1071-1-ND	.47	.44	.41	—	—	KSC141G	
300gF	凹槽	鸥翼形	银	401-1751-1-ND	.41	.38	.35	401-1751-2-ND	2,000	225.00/M	KSC141GLFS
300gF	凹槽	J形引线	银	401-1072-1-ND	.47	.44	.41	—	—	KSC141J	
300gF	凹槽	J形引线	银	401-1752-1-ND	.41	.38	.35	—	—	KSC141JLFS	
550gF	凹槽	鸥翼形	银	401-1073-1-ND	.49	.45	.42	—	—	KSC151G	
550gF	凹槽	鸥翼形	银	401-1753-1-ND	.54	.51	.46	—	—	KSC151GLFS	
550gF	凹槽	J形引线	银	401-1074-1-ND	.49	.45	.42	—	—	KSC151J	
550gF	凹槽	J形引线	银	401-1754-1-ND	.54	.51	.46	401-1754-2-ND	2,000	300.60/M	KSC151JLFS
120gF	软 3.5mm	鸥翼形	银	401-1457-1-ND	.47	.44	.41	—	—	KSC201G	
120gF	软 3.5mm	鸥翼形	银	401-1755-1-ND	.43	.40	.37	401-1755-2-ND	2,000	239.40/M	KSC201GLFS
120gF	软 3.5mm	J形引线	银	401-1458-1-ND	.47	.44	.41	—	—	KSC201J	
120gF	软 3.5mm	J形引线	银	401-1756-1-ND	.43	.40	.37	401-1756-2-ND	2,000	239.40/M	KSC201JLFS
160gF	软 3.5mm	J形引线	银	CKN9195CT-ND	.42	.39	.36	CKN9195TR-ND	2,000	234.00/M	KSC222J LFS
160gF	软 3.5mm	鸥翼形	银	CKN9194CT-ND	.42	.39	.36	CKN9194TR-ND	2,000	234.00/M	KSC222J LFS
200gF	软 3.5mm	鸥翼形	银	401-1757-1-ND	.41	.39	.35	401-1757-2-ND	2,000	228.60/M	KSC221GLFS
200gF	软 3.5mm	J形引线	银	401-1758-1-ND	.41	.39	.35	401-1758-2-ND	2,000	228.60/M	KSC221JLFS
160gF	软 3.5mm	鸥翼形	金	401-1459-1-ND	.59	.54	.50	—	—	KSC223G	
160gF	软 3.5mm	鸥翼形	金	401-1759-1-ND	.58	.54	.49	401-1759-2-ND	2,000	234.00/M	KSC223GLFG
160gF	软 3.5mm	J形引线	金	401-1460-1-ND	.59	.54	.50	—	—	KSC223J	
160gF	软 3.5mm	J形引线	金	401-1760-1-ND	.58	.54	.49	—	—	KSC223JLFG	
300gF	软 3.5mm	鸥翼形	金	401-1269-1-ND	.66	.62	.57	—	—	KSC243G	
300gF	软 3.5mm	鸥翼形	金	401-1763-1-ND	.59	.55	.51	401-1763-2-ND	2,000	329.40/M	KSC243GLFG
300gF	软 3.5mm	J形引线	金	401-1764-1-ND	.59	.55	.51	401-1764-2-ND	2,000	329.40/M	KSC243JLFG
350gF	软 3.5mm	鸥翼形	银	401-1761-1-ND	.42	.39	.36	401-1761-2-ND	2,000	234.00/M	KSC241GLFS
350gF	软 3.5mm	J形引线	银	401-1078-1-ND	.56	.52	.48	—	—	KSC241J	
350gF	软 3.5mm	J形引线	银	401-1762-1-ND	.42	.39	.36	401-1762-2-ND	2,000	234.00/M	KSC241JLFS
160gF	硬 3.5mm	鸥翼形	银	401-1765-1-ND	.42	.39	.36	401-1765-2-ND	2,000	234.00/M	KSC321GLFS
160gF	硬 3.5mm	J形引线	银	401-1701-1-ND	.45	.42	.38	—	—	KSC321J	
160gF	硬 3.5mm	J形引线	银	401-1766-1-ND	.42	.39	.36	401-1766-2-ND	2,000	234.00/M	KSC323J LFS
160gF	硬 3.5mm	鸥翼形	金	401-1461-1-ND	.57	.53	.48	—	—	KSC323G	
160gF	硬 3.5mm	鸥翼形	金	401-1767-1-ND	.55	.51	.47	401-1767-2-ND	2,000	302.40/M	KSC323GLFG
160gF	硬 3.5mm	J形引线	金	401-1462-1-ND	.57	.53	.48	—	—	KSC323J	
160gF	硬 3.5mm	J形引线	金	401-1768-1-ND	.55	.51	.47	401-1768-2-ND	2,000	302.40/M	KSC323JLFG
300gF	硬 3.5mm	鸥翼形	银	401-1463-1-ND	.47	.44	.40	—	—	KSC341G	
300gF	硬 3.5mm	鸥翼形	银	401-1769-1-ND	.47	.44	.40	401-1769-2-ND	2,000	234.00/M	KSC341GLFS
300gF	硬 3.5mm	J形引线	银	401-1267-1-ND	.47	.44	.40	—	—	KSC341J	
300gF	硬 3.5mm	J形引线	银	401-1770-1-ND	.42	.39	.36	401-1770-2-ND	2,000	234.00/M	KSC341JLFS
300gF	硬 3.5mm	鸥翼形	金	401-1464-1-ND	.57	.53	.49	—	—	KSC343G	
300gF	硬 3.5mm	鸥翼形	金	401-1771-1-ND	.55	.51	.47	401-1771-2-ND	2,000	302.40/M	KSC343GLFG
300gF	硬 3.5mm	J形引线	金	401-1465-1-ND	.57	.53	.49	—	—	KSC343J	
300gF	硬 3.5mm	J形引线	金	401-1772-1-ND	.55	.51	.47	401-1772-2-ND	2,000	302.40/M	KSC343JLFG
550gF	硬 3.5mm	鸥翼形	金	401-1272							



**密封表面贴装触摸开关 KSC 系列 - 可清洗, 完全密封 (IP67) (接上页)**

操作力	触动器	端子	触点材质	Digi-Key 零件编号	剪切带 单价			Digi-Key 零件编号	带卷		C&K Components 零件编号
					1	25	100		数量	价格	
550gF	硬 3.5mm	鸥翼形	银	401-1773-1-ND	.47	.44	.40	401-1773-2-ND	2,000	261.00/M	KSC351GLFS
550gF	硬 5.5mm	J 形引线	银	401-1774-1-ND	.47	.44	.40	401-1774-2-ND	2,000	261.00/M	KSC351JLFS
120gF	软 5.2mm	J 形引线	银	401-1466-1-ND	.60	.56	.51	401-1466-2-ND	1,000	333.00	KSC401J50SH
120gF	软 5.2mm	J 形引线	银	401-1775-1-ND	.52	.48	.44	401-1775-2-ND	1,000	288.00	KSC401J 50SH LFS
120gF	软 5.2mm	J 形引线	金	401-1776-1-ND	.81	.75	.69	401-1776-2-ND	1,000	450.00	KSC403J 50SH LFG
140gF	软 5.2mm	鸥翼形	银	401-1468-1-ND	.53	.49	.45	—	—	—	KSC411G70SH
140gF	软 5.2mm	鸥翼形	银	401-1777-1-ND	.51	.48	.44	401-1777-2-ND	1,000	282.60	KSC411G 70SH LFS
140gF	软 5.2mm	J 形引线	银	401-1469-1-ND	.53	.49	.45	—	—	—	KSC411J70SH
140gF	软 5.2mm	J 形引线	银	401-1778-1-ND	.51	.48	.44	401-1778-2-ND	1,000	282.60	KSC411J 70SH LFS
160gF	软 5.2mm	鸥翼形	银	CKN9198CT-ND	.50	.47	.43	CKN9198TR-ND	1,000	279.00	KSC422G 70SH LFS
160gF	软 5.2mm	J 形引线	银	401-1780-1-ND	.75	.70	.58	401-1780-2-ND	1,000	271.80	KSC421J 70SH LFS
160gF	软 5.2mm	直角	银	CKN9199CT-ND	.46	.43	.39	CKN9199TR-ND	1,000	254.00	KSC422J 70SH LFS
170gF	软 5.2mm	直角	银	401-1781-ND	.75	.70	.58	—	—	—	KSC421V30ACT2.95LFS
320gF	软 5.2mm	鸥翼形	银	401-1081-1-ND	.49	.45	.42	—	—	—	KSC441G70SH
300gF	软 5.2mm	鸥翼形	银	401-1783-1-ND	.50	.47	.43	401-1783-2-ND	1,000	279.00	KSC441G 70SH LFS
300gF	软 5.2mm	J 形引线	银	401-1784-1-ND	.50	.47	.43	401-1784-2-ND	1,000	279.00	KSC441J 70SH LFS
300gF	软 5.2mm	J 形引线	金	401-1785-1-ND	.73	.68	.62	401-1785-2-ND	1,000	442.80	KSC443J 70SH LFG
320gF	软 5.2mm	J 形引线	银	CKN9197CT-ND	.52	.48	.44	CKN9197TR-ND	1,000	288.00	KSC442J 70SH LFS
320gF	软 5.2mm	鸥翼形	银	CKN9196CT-ND	.52	.48	.44	CKN9196TR-ND	1,000	288.00	KSC442G 70SH LFS
160gF	摆臂 5.6mm	鸥翼形	银	401-1907-1-ND	.53	.50	.46	401-1907-2-ND	1,000	295.20	KSC521G ROHS
160gF	硬 7.7mm	鸥翼形	银	401-1786-1-ND	.56	.52	.48	401-1786-2-ND	750	233.55	KSC621JLFS
160gF	硬 7.7mm	J 形引线	银	401-1748-1-ND	.51	.48	.44	401-1748-2-ND	750	233.55	KSC621J LFS
300gF	硬 7.7mm	鸥翼形	银	401-1787-1-ND	.58	.54	.49	401-1787-2-ND	750	238.95	KSC641GLFS
300gF	硬 7.7mm	J 形引线	银	401-1788-1-ND	.58	.54	.49	401-1788-2-ND	750	238.95	KSC641JLFS
声音可调的触摸开关: 符合 RoHS 规范要求											
340gF	软 5.2mm	鸥翼形	银	CKN9200CT-ND	.56	.52	.48	CKN9200TR-ND	1,000	310.00	KSC441G ST1 LFS
340gF	软 5.2mm	J 形引线	银	CKN9201CT-ND	.56	.52	.48	CKN9201TR-ND	1,000	310.00	KSC441J ST1 LFS
340gF	软 5.2mm	鸥翼形	银	CKN9202CT-ND	.58	.54	.49	CKN9202TR-ND	1,000	320.00	KSC441G ST2 LFS
340gF	软 5.2mm	J 形引线	银	CKN9203CT-ND	.58	.54	.49	CKN9203TR-ND	1,000	320.00	KSC441J ST2 LFS

◆ 符合 RoHS 规范要求 † 散装 ‡ 长寿命版本 † KSC5. 未密封

**K5V 系列发光触摸开关**

特点: • 镀金圆顶触点 • 优秀的人体工学设计 • 高亮度 LED 技术规格 • 功能: 瞬时动作, SPDT 机械特性: • 操作力: 400gF • 工作寿命: 25,000 次操作电气 • 最小/最大功率: 0.02VA/10VA • 最小/最大电压: 20mVDC-32VDC • 最小/最大电流: 0.1mA-100mA 环境特性: • 工作温度: -40°C ~ 85°C

尺寸: 英寸 (mm)



图	颜色	Digi-Key 零件编号	1	25	100	Digi-Key 零件编号	带卷价格	C&K 零件编号
直角穿孔								
1	蓝	401-1854-ND	6.50	5.78	5.06	—	—	K5V1BU43T
	绿	401-1657-ND	8.13	7.51	6.89	—	—	K5V1GN43T
	红	401-1658-ND	9.20	8.50	7.79	—	—	K5V1RD43T
	黄-绿	401-1659-ND	7.23	6.68	6.13	—	—	K5V1YG43T
直角穿孔 (带用于灯管延长线的锁销)								
1	绿	401-1859-ND	5.13	4.56	3.99	—	—	K5V2GN43TP3
直角 SMT								
2	蓝	401-1852-1-ND	11.61	10.72	9.83	401-1852-2-ND	2121.77	K5V1BU43G
	绿	401-1662-1-ND	10.03	9.27	8.49	—	—	K5V1GN43G
	白	401-1855-1-ND	9.69	8.95	8.21	—	—	K5V1WH43G
	黄-绿	401-1664-1-ND	8.52	7.87	7.22	—	—	K5V1YG43G
面板安装								
3	蓝	401-1853-ND	6.15	5.47	4.79	—	—	K5V1BU43P
	黄-绿	401-1653-ND	6.07	5.61	5.14	—	—	K5V1YG43P

**KS 系列按键开关**

触点材质:

Q 可移动触点: 镀铜, 镀银, 在最大 50VAC/DC 时最大为 25mA。固定触点和所有端子: 铜合金, 镀银  
B 触点: 镀金端子: 镀金额定值: 在最大 50VAC/DC 时最大为 25mA

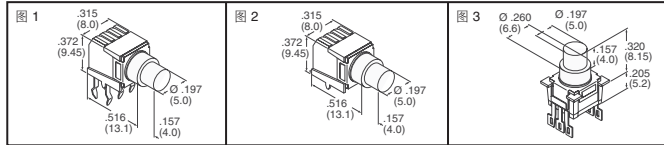
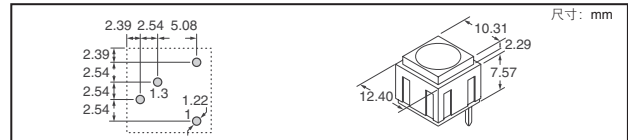

电路	开关功能	触点材质	帽盖颜色	Digi-Key 零件编号	1	25	100	C&K 零件编号
KS 瞬时按键开关 (不可清洗)								
SPST	瞬时 (NO)	B	白	CKN4077-ND	2.79	2.24	1.77	KS11R21CBD
		Q	白	CKN4078-ND	1.81	1.45	1.15	KS11R21CQD
		Q	白	CKN1590-ND	3.20	2.56	2.03	KS11R21CQE
		B	黑	CKN4079-ND	2.79	2.24	1.77	KS11R22CBD
		Q	黑	CKN4080-ND	1.81	1.45	1.15	KS11R22CQD
		Q	黑	CKN1591-ND	3.20	2.56	2.03	KS11R22CQE
SPDT	瞬时	B	红	CKN4081-ND	2.86	2.29	1.82	KS11R23CBD
		Q	红	CKN4082-ND	1.81	1.45	1.15	KS11R23CQD
		Q	蓝	CKN1592-ND	2.14	1.72	1.36	KS11R27CQD
		Q	白	CKN1593-ND	2.60	2.09	1.65	KS12R21CQD
		B	黑	CKN1594-ND	4.46	3.58	2.83	KS12R22CBE
		Q	黑	CKN1595-ND	2.60	2.09	1.65	KS12R22CQD
Q	黑	CKN1596-ND	3.34	2.68	2.12	KS12R22CQE		

**RACON 短行程按键开关**

RACON 短行程按键开关为您提供极高的开关可靠性, 且所占空间极小, 可作为单键以排或按键块安排。

技术规格:

- 工作温度: -40°C ~ 80°C
- 工作寿命: 1,000,000 次
- 最大额定电压: 42V
- 最大额定电流: 100mA

尺寸: mm



图	说明	Digi-Key 零件编号	1	25	100	C&K 零件编号
开关						
1	RACON 8. 330gF, 外向型端子	CKN9361-ND	2.67	2.14	1.70	1.14100.5010000
2	RACON 8. 330gF, 内向型端子	CKN9362-ND	2.83	2.27	1.80	1.14100.5020000
3	RACON 8. 330gF, 表面贴装	CKN9363CT-ND†	2.71	2.50	2.30	1.14100.5030000
4	RACON 8. 330gF, 表面贴装	CKN9363TR-ND	1499.00/1,000	—	—	1.14100.5030000
4	RACON 12. 360gF, 外向型端子	CKN9364-ND	2.77	2.22	1.76	1.14001.5010000
5	RACON 12. 360gF, 内向型端子	CKN9365-ND	2.77	2.22	1.76	1.14001.5020000
6	RACON 12. 360gF, 表面贴装	CKN9366CT-ND†	2.97	2.74	2.52	1.14001.5030000
7	RACON 12. 360gF, 表面贴装	CKN9366TR-ND	1232.55/750	—	—	1.14001.5030000
6	RACON 12V. 360gF, PCB 安装	CKN9367-ND	3.96	3.18	2.51	1.14001.5050000
8	RACON 12i. 330gF, 红色 LED	CKN9368-ND	16.12	12.90	10.21	1.14001.5510000
8	RACON 12i. 330gF, 绿色 LED	CKN9205-ND	16.12	12.90	10.21	1.14001.5520000
8	RACON 12i. 330gF, 黄色 LED	CKN9206-ND	16.12	12.90	10.21	1.14001.5530000

图	说明	Digi-Key 零件编号	1	25	100	C&K 零件编号
配件						
9	冲杆, H=6.5mm x 8mm 直径	CKN9369-ND	.48	.39	.31	5.46167.3010209
9	冲杆, H=7mm x 8mm 直径	CKN9207-ND	.48	.39	.31	5.46167.0900209
9	冲杆, H=6.5mm x 11.5mm 直径	CKN9208-ND	.48	.39	.31	5.46167.2270209
9	冲杆, H=7mm x 11.5mm 直径	CKN9370-ND	.48	.39	.31	5.46167.0420209
9	冲杆, H=7mm x 14.5mm 直径	CKN9209-ND	.48	.39	.31	5.46168.0420209
9	冲杆, H=9.7mm x 14.5mm 直径	CKN9371-ND	.48	.39	.31	5.46168.0430209
9	冲杆, H=7mm x 19mm 直径	CKN9210-ND	.31	.25	.20	5.46169.0420209
9	冲杆, H=12.5mm x 19mm 直径	CKN9372-ND	.48	.39	.31	5.46169.0440209
10	冲杆, H=7mm x 14mm 方形	CKN9211-ND	.48	.39	.31	5.46001.0570209
10	冲杆, H=12.5mm x 14mm 方形	CKN9373-ND	.48	.39	.31	5.46001.0590209

† 剪切带 † 带卷

全部产品均以美元计价。

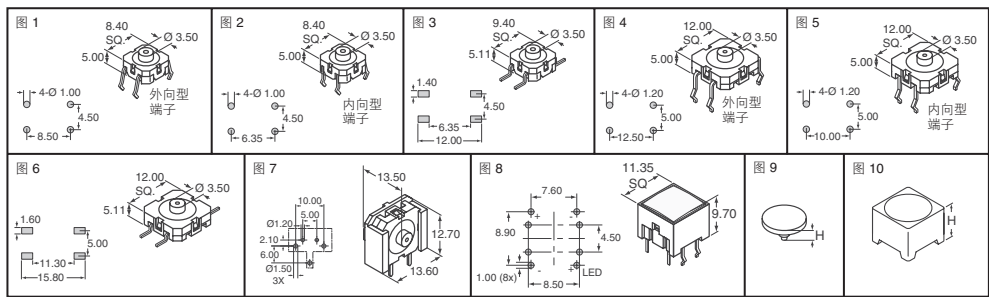
免费电话: 10800-1527031 (China Telecom - 中国电讯) — 10800-8527031 (CNCG - 中国网通)